



Submerged Arc Welding Consumables

Hobart®: Your Partner in Submerged Arc Welding Excellence



Proven performance. Quality. Reliability. Integrity. Innovation. These are foundations that businesses build upon to achieve success. No organization does it all alone; they win with exceptional partners at their side. Hobart operates under these same principles by providing more than just filler metals to our customers.



Hobart delivers proven performance with a wide range of Submerged Arc welding solutions to solve specific challenges. Solutions that grow and evolve along with your needs — solutions that can help grow your business. Hobart has a proven track record of helping our customers find the right filler metal for their unique needs. You'll experience our passion for excellence in the precise formulations and exacting processes we use to produce filler metals and fluxes. Consumables that produce consistent, repeatable Submerged Arc results you can count on to optimize your welding processes.



By partnering with Hobart, you'll benefit from our vast industry experience. You'll also benefit from the knowledge developed in our testing facilities, which include single- and multi-wire installations to simulate and develop productive welding procedures for industrial segments. Applications include: longitudinal and spiral pipe mills, wind tower production, pressure vessel fabrication and shipbuilding.



Jointly, Miller and Hobart offer expertise in engineering and innovation to tackle any project challenge your business faces. You will experience a total solution when you pair our Hobart® consumables with the advanced new line of Miller® Submerged Arc welding equipment — power sources, torches and tractors. For a simple and cost-effective heating process that can deliver fast and consistent heat, incorporate the Miller ProHeat™ 35 induction heating system for pre-heat applications. As ITW Welding companies, Miller and Hobart share a commitment to your complete satisfaction. With us, you can create the highest-quality results.

In a very literal sense, filler metals are “the tie that binds,” creating the welds that we see every day and make our world possible. At Hobart, we earn your business with trust in quality, service and a proven record of innovative solutions developed with our customer partners. Our partnership is truly what sets us apart to do great things with you.

Table of Contents

Selection Tables

Flux Selection Guide by Industrial Application	5
Flux Selection Quick Guide	6
SubCOR™ Metal-Cored Wire Selection Quick Guide	7
SubCOR™ SL Cored Wire Selection Quick Guide	8
Tube-Alloy® Quick Guide	9
SAW Approval Summary	10
SDX Solid Wire and Cromastrip Strip Range	11
Flux Selection by ISO Classification	12
Flux Selection by AWS Wire Classification	14
Flux Selection by SDX Solid Wire	15
Flux Selection by SubCOR™ Cored Wire	15

Consumables

SWX 110 - EN ISO 14174: S A AB 1 67 AC H5	16
SWX 120 - EN ISO 14174: S A AB 1 57 AC H5	18
SWX 130 - EN ISO 14174: S A AB 1 67 AC H5	20
SWX 135 - EN ISO 14174: S A AB 1 67 AC H5	22
SWX 140 - EN ISO 14174: S A FB 1 57 AC H5	24
SWX 150 - EN ISO 14174: S A FB 1 55 AC H5	26
SWX 160 - EN ISO 14174: S A FB 1 55 AC H5	30
SWX 220 - EN ISO 14174: S A AF 2 DC	32
SWX 282 - EN ISO 14171: S A AF 2 DC	34
SWX 305 - EN ISO 14174: S A AAS 2B DC	35
SWX 330 - EN ISO 14174: ES A FB 2B DC	36
SWX 340 - EN ISO 14174: ES A FB 2B DC	37
SWX 382 - EN ISO 14174: ES A AF 2B DC and S A AF 2 AC	38
SWX HF-N	39
SWX 010 - Powder Backing for One-Sided Welding	40
Approval Certificates	41
Packaging Solutions	42
Storage and Handling Recommendations	43
Full-Performance Submerged Arc Welding Pays Back	44
Hobart SubCOR™ Cored Wires for Submerged Arc Welding	46
Improved Productivity from SubCOR™ Metal-Cored Wires	48
Flux-Cored Micro Injection	50
Submerged Arc Welding Process	52
SAW and ESW Strip Cladding	64
Submerged Arc Power Sources and AC Wave Balance	66
Troubleshooting	70
Packaging and Pallet Information	72
Conversion Charts	74
Classification Standards	75

NOTE: With this catalog, Hobart presents its global range of Hobart Submerged Arc welding consumables under the product names SWX for fluxes, SDX for solid wires and SubCOR for cored wires. Earlier products marketed in individual countries under brand names like Hobart, Elga and Tien Tai continue to be available until further notice.

Disclaimer: The information contained or otherwise referenced herein is for reference purposes only and is presented only as “typical”. Typical data are those obtained when welding and testing are performed in accordance with applicable AWS and/or EN ISO specifications. Other tests and procedures may produce different results and typical data should not be assumed to yield similar results in a particular application or weldment. No data is to be construed as a recommendation for any welding condition or technique not controlled by Miller and Hobart. Miller and Hobart do not assume responsibility for any results obtained by persons over whose methods it has no control. It is the user’s responsibility to determine the suitability of any products or methods mentioned herein for a particular purpose. In light of the foregoing, Miller and Hobart specifically disclaim any liability incurred from reliance on such information, and disclaims all guarantees and warranties, express or implied, including warranties of merchantability and fitness for a particular purpose, and further disclaims any liability for consequential or incidental damages of any kind, including lost profits.

Best-in-Class Submerged Arc Welding Consumables

Developed *for* our customers. Developed *with* our customers.

Your success is our success. That's why Hobart takes great care to fully understand your unique Submerged Arc welding challenges. We use that knowledge to develop filler metal and flux solutions that truly meet your needs, without compromise — solutions that are ideal for use with Miller® SubArc Digital Series equipment.

This handbook is a showcase of many solutions we've developed with customers like you. Here, you'll find best-in-class filler metals we've created for welding carbon steels, stainless steels and nickel-base alloys. You'll see how Hobart supports ESW strip cladding processes with strip electrodes and fluxes designed to increase deposition rates over conventional methods. You'll find special flux and wire combinations that have been developed to meet the specific requirements of demanding industries, including pressure

vessel fabrication, offshore construction, wind towers and pipe mills.

Hobart solutions include:

- SWX — submerged arc fluxes
- SDX — submerged arc solid wires
- SubCOR® — submerged arc cored wires
- SubCOR® SL — submerged arc seamless cored wires
- Cromastrip — submerged arc and electroslag strips

Hobart delivers proven performance, solving specific challenges with a wide range of Submerged Arc welding solutions today and in the future. Hobart is prepared to grow and evolve along with your needs. To find the solution you're looking for, **contact your Hobart Submerged Arc professional today.**



Flux Selection Guide by Industrial Application

		Joining								Strip cladding				Hard facing	
		Non- and low-alloyed								Stain- less	Ni alloy	SAW	ESW		
Depending on requirements		SWX 110	SWX 120	SWX 130	SWX 135	SWX 140	SWX 150	SWX 160	SWX 220	SWX 282	SWX 305	SWX 330	SWX 340	SWX 382	SWX HF-N
Civil construction	Beams, bridges, buildings	✓													
Cranes	Normal strength steel	✓													
	High strength steel					✓	✓	✓							
Offshore	Constructions	✓				✓	✓	✓							
	Process equipment							✓	✓	✓					✓
Pipelines	Double jointing	✓				✓	✓								
Pipe mills	Longitudinal			✓					✓						
	Spiral	✓			✓										
	Surfacing										✓	✓	✓	✓	
Power generation	Boilers	✓				✓	✓	✓	✓		✓	✓	✓	✓	
	Nuclear						✓	✓	✓		✓	✓			
	Tube to fin	✓													
Pressure vessels	Joining	✓	✓			✓	✓	✓	✓						
	Surfacing										✓	✓	✓	✓	
Process industry	Hydrocrackers						✓	✓							
	Pulp and paper								✓	✓					
Repair	Buildup														✓
Shipbuilding	Butt and fillet welding	✓													
	Handling equipment					✓									
Storage tanks	Chemical tanks								✓						
	LPG tanks								✓						
	Oil tanks	✓	✓												
Steel mills	Continuous caster rollers														✓
	Miscellaneous rollers														✓
Transport	Beams for trucks and rail cars	✓													
	Heavy equipment	✓	✓												
	Wheels	✓													
Wind energy	Monopiles, tri-pods, jackets		✓				✓								
	Towers	✓	✓												
Hard facing															✓



Flux Selection Quick Guide

SWX 110	Multi-purpose flux applied in a variety of industries
	Medium-basic general-purpose flux allowing high travel speeds
	Covers a wide range of applications
	For mild steel and medium-tensile fine-grained steel with impact toughness requirements down to -40°C (-40°F)
SWX 120	Flux for wind tower fabrication
	Suitable for circumferential and longitudinal multi-layer welds
	Productive flux with good impact toughness down to -50°C (-58°F), using standard-quality S2 and S2Si solid wires
	Single- and multi-wire operations
SWX 130	Flux for longitudinal pipe mills
	High current carrying capacity
	High welding speed and good mechanical properties in two-run welding with up to five wires
	Flat and wide bead profile with smooth wetting
SWX 135	Flux for spiral pipe mills
	High welding speed and good mechanical properties in two-run welding with up to three wires
	Fast freezing slag
	Flat and wide bead profile with smooth wetting
SWX 140	Multi-purpose flux for applications with increased toughness demands
	Versatile and productive basic flux for applications with increased low-temperature toughness demands down to -50°C (-58°F)
	Meets toughness requirements down to -60°C (-76°F) with SubCOR™ cored wires
	For single-, two-run or multi-layer welds in single- or multi-wire setups
SWX 150	High-basicity flux for demanding applications
	For demanding applications, such as offshore, pressure vessel, cryogenic and nuclear fabrication
	Excellent impact toughness down to -60°C (-76°F) + CTOD
	Works in single- and multi-wire applications, but also for narrow gap welding
SWX 160	Ultra-clean high-basicity flux for outstanding X-factor and high-strength welding
	For creep-resistant applications with low-impurity requirements (X-factor) inclusive of step cooling
	Excellent slag detachability makes it suitable for both high-strength steel and narrow gap welding applications
	Provides good toughness properties in creep-resistant applications, particularly with SubCOR cored wires
SWX 220	Flux for stainless steel joining
	Joining of austenitic, duplex and super duplex stainless steels, dissimilar joints and higher-alloyed stainless steel grades
	Excellent slag detachability in multi-run welds
SWX 282	Flux for joining Ni-base alloys
	Single- or multi-run joining of Ni-base alloys, such as Alloy 82, Alloy 600 and Alloy 625
	Excellent impact toughness down to -196°C (-320°F)
SWX 305	Flux for SAW strip cladding
	Submerged Arc strip cladding flux for two- or more layer welding with stainless strips
	Smooth bead appearance and easy slag removal
SWX 330	Flux for standard-speed ESW strip cladding
	ESW strip cladding flux with high-current carrying capacity for standard-speed welding
	High current carrying capacity
SWX 340	Flux for high-speed ESW strip cladding
	ESW strip cladding flux for traveling speeds up to 45 cm/min (17.7 IPM)
	One- or two-layer high-speed cladding with outstanding slag detachability and bright deposit
SWX 382	Flux for ESW strip cladding and SAW overlay welding with nickel base
	Electroslag strip cladding with Ni-base strips in one or two layers
	Ni-base Submerged Arc overlay welding with Ni-base wire
SWX HF-N	Flux for Submerged Arc hard surfacing
	For stringer or oscillated welding in single- or multi-layer applications
	Extremely heat resistant with a variety of Tube-Alloy® cored wires for desired weld metal properties
SWX 010	Powder backing for one-sided welding on copper weld metal supports
	Has no influence on weld metal properties
	Gives a regular, smooth root pass

SubCOR™ Metal-Cored Wire Selection Quick Guide

Product	Features
SubCOR EM12K-S	<p>General-purpose cored wire electrode for Submerged Arc welding of non-alloyed steels</p> <p>Higher deposition rate than solid wires</p> <p>Similar in chemistry to AWS A5.17: EM12K</p> <p>Suitable fluxes: SWX 110, SWX 120, SWX 140 and SWX150</p>
SubCOR EM13K-S	<p>General-purpose cored wire electrode for Submerged Arc welding of non-alloyed steels</p> <p>Higher deposition rate than solid wires and at the same time improved impact toughness properties</p> <p>Similar in chemistry to AWS A5.17: EM13K</p> <p>Suitable fluxes: SWX 110, SWX 120 and SWX150</p>
SubCOR EM13K-S MOD	<p>General-purpose cored wire electrode for Submerged Arc welding of non-alloyed steels with PWHT</p> <p>Higher deposition rate than solid wires and at the same time improved impact toughness properties</p> <p>Similar in chemistry to AWS A5.17: EM13K</p> <p>Suitable fluxes: SWX 110, SWX 120, SWX 140 and SWX 150</p>
SubCOR 92-S	<p>Low-alloyed cored wire electrode for high-strength applications: AWS A5.23 chemistry M1</p> <p>Designed for tensile strength levels above 550 MPa (80 ksi)</p> <p>Like all SubCOR wires it provides improved deposition rates compared to solid wires</p> <p>Suitable fluxes: SWX 140 and SWX 150</p>
SubCOR F2-S	<p>Low-alloyed wire for high-strength applications: AWS A5.23 chemistry F2</p> <p>Designed for tensile strength levels over 620 MPa (90 ksi)</p> <p>Suitable flux: SWX 150</p>
SubCOR 100F3-S	<p>Low-alloyed wire for high-strength applications: AWS A5.23 chemistry F3</p> <p>Designed for tensile strength levels over 690 MPa (100 ksi)</p> <p>Suitable fluxes: SWX 140 and SWX 150</p>
SubCOR 120-S	<p>Low-alloyed cored wire electrode for high-strength applications: AWS A5.23 chemistry M4</p> <p>Designed for tensile strength levels above 760 MPa (110 ksi)</p> <p>Like all SubCOR wires it provides improved deposition rates compared to solid wires</p> <p>Suitable fluxes: SWX 150 and SWX 160</p>
SubCOR N1-S	<p>Low-alloyed cored wire electrode where a 1% nickel deposit is required: AWS A5.23 chemistry Ni1</p> <p>Designed for tensile strengths above 480 MPa (70 ksi)</p> <p>Suitable fluxes include SWX 150</p>
SubCOR W-S	<p>Low-alloyed wire for copper-alloyed weathering steels</p> <p>Very good impact properties down to -50°C (-60°F)</p> <p>Suitable flux: SWX 150</p>
SubCOR B2-S	<p>Cr-Mo alloyed wire for creep-resistant steels: AWS A5.23 chemistry B2</p> <p>Like all SubCOR wires it provides improved deposition rates compared to solid wires</p> <p>Suitable flux: SWX 150</p>
SubCOR B3-S	<p>Cr-Mo alloyed wire for creep-resistant steels: AWS A5.23 chemistry B3</p> <p>Like all SubCOR wires it provides improved deposition rates compared to solid wires</p> <p>Suitable flux: SWX 150</p>

SubCOR™ SL Cored Wire Selection Quick Guide

Product	Features
SubCOR SL 731	General-purpose cored wire electrode for Submerged Arc welding of non-alloyed steels Higher deposition rate than solid wires and at the same time improved impact toughness properties Recommended instead of SDX S2, SDX EM13K, SDX S2Si-EM12K or SDX S3Si-EH12K solid wires Suitable fluxes: SWX 110, SWX 120 and SWX 150
SubCOR SL 840 HC	Specifically designed for offshore construction, pressure vessels and double jointing for pipelines Gives excellent impact toughness properties also in stress relieved condition Suitable flux: SWX 140
SubCOR SL 735 1W-5W	For Flux Cored Micro Injection (FMI) in combination with other cored and/or solid wires Available in five versions with specific chemistry for single-, tandem- and up to five-wire setups For significantly enhanced impact properties both in single- and two-run applications Suitable fluxes: SWX 130 and SWX 135
SubCOR SL 741	Low-alloyed cored wire electrode for high-strength applications Designed for yield strength levels up to 550 MPa (80 ksi) Like all SubCOR wires it provides improved deposition rates compared to solid wires Suitable fluxes: SWX 140 and SWX 150
SubCOR SL 742	Low-alloyed wire for high-strength applications Designed for yield strength levels up to 690 MPa (100 ksi) Suitable fluxes: SWX 150 and SWX 160
SubCOR SL 745	Low-alloyed wire for high-strength applications Designed for yield strength levels up to 890 MPa (130 ksi) Suitable flux: SWX 150
SubCOR SL 281 Cr	Low-alloyed wire for copper-alloyed weathering steels Very good impact properties down to -40°C (-40°F) Suitable flux: SWX 110
SubCOR SL P1	Low-alloyed wire electrode for creep-resistant applications — nominal weld metal deposit 0.5% Mo Comparable strength level, but significantly higher impact toughness than SDXS2Mo-EA2 solid wire Suitable flux: SWX 150
SubCOR SL P1 MOD	The same basic features as SubCOR SL P1, but with an addition of 0.5% Ni and 0.5% V Like all SubCOR wires it provides improved deposition rates compared to solid wires Suitable flux: SWX 150
SubCOR SL P11	Low-alloyed wire for creep-resistant steels — nominal weld metal deposit 1% Cr and 0.5% Mo Comparable strength level, but significantly higher impact toughness than SDX CrMo1-EB2R solid wire Suitable flux: SWX 150
SubCOR SL P12 MOD	Low-alloyed wire for creep-resistant steels — nominal weld metal deposit 1% Cr, 1% Ni and 0.25% V For joining of CrMoV-steels up to 550°C (1020°F) Suitable flux: SWX 150
SubCOR SL P22	For joining of creep-resistant and pressure-hydrogen-resistant 2¼Cr1Mo-steels Meets requirements of step cooling due to very low weld metal contaminations Suitable flux: SWX 150
SubCOR SL P24	For joining of creep-resistant and pressure-hydrogen-resistant 2¼Cr1MoV-steels Meets requirements of step cooling due to very low weld metal contaminations Suitable flux: SWX 150
SubCOR SL P36	For economic joining of Mo-alloyed creep-resistant steels up to 500°C (930°F) — adds Ni max. 1% Ideal for production and repair welding Suitable flux: SWX 150
SubCOR SL P5	High-alloy cored wire electrode for creep-resistant steels with 5% Cr and 0.5% Mo For surfacing and joining of similar creep-resistant and pressure-hydrogen-resistant boiler tube steels Creep- and scale-resistant up to 600°C (1100°F) Suitable flux: SWX 150
SubCOR SL P9	For surfacing and joining of 9Cr1Mo creep-resistant and pressure-hydrogen-resistant boiler tube steels Creep- and scale-resistant up to 600°C (1100°F) Suitable flux: SWX 150
SubCOR SL P91	For surfacing and joining of 9Cr1MoNbV creep-resistant and pressure-hydrogen-resistant boiler tube steels Creep- and scale-resistant up to 600°C (1100°F) Suitable fluxes: SWX 150 and SWX 160
SubCOR SL P92	For surfacing and joining of 10Cr1MoVW creep-resistant and pressure-hydrogen-resistant boiler tube steels Creep- and scale-resistant up to 650°C (1200°F) Suitable flux: SWX 150

Tube-Alloy® Quick Guide

Product	Features
Tube-Alloy 242-S MOD	General-purpose low-alloy steel overlay product provides good resistance to metal-to-metal wear, but is still machinable Typical hardness range (as deposited): 30–40 Rc Suitable flux: SWX HF-N
Tube-Alloy 810-S	Martensitic H-10 type tool-steel deposit is suitable for use as an overlay in high-impact, high-abrasion applications Typical applications: table rolls, cold mill leveler rolls, plate leveler back-up rolls, straightener rolls, down coiler pinch rolls, aluminum mill edger rolls, primary roughing mill rolls Typical hardness range (as deposited): 45–55 Rc Suitable flux: SWX HF-N
Tube-Alloy 8620	Used for build-up on mild steel and low-alloy steel components; offers excellent machinability Typical deposit hardness is less than Tube-Alloy BU-S Typical hardness range (as deposited): 15–20 Rc Suitable flux: SWX HF-N
Tube-Alloy 865-S MOD	Modified stainless steel deposit composition offers the ultimate resistance to both thermal fatigue cracking and loss of toughness from tempering Typical applications: split-body continuous caster rolls Typical hardness range (as deposited): 45–50 Rc Suitable flux: SWX HF-N
Tube-Alloy 875-S	Deposits a martensitic stainless steel alloy that offers the ultimate corrosion resistance in steel mill roll applications; provides good resistance to metal-to-metal wear and thermal fatigue Typical applications: wide and split-body continuous caster rolls Typical hardness range (as deposited): 45 Rc Suitable flux: SWX HF-N
Tube-Alloy 952-S	Modified stainless steel deposit provides excellent toughness for high-impact applications, as well as good resistance to metal-to-metal wear Suitable for service temperatures up to 566°C (1050°F), but should not be used where thermal fatigue cracking is a primary concern Typical applications: straightener rolls, plate leveler rolls, edger rolls, descale rolls Typical hardness range (as deposited): 40–50 Rc Suitable flux: SWX HF-N
Tube-Alloy A250-S	Produces a modified 420 stainless steel deposit that offers good resistance to thermal corrosion and fatigue cracking Typical applications: split-body continuous caster rolls, table rolls Typical hardness range (as deposited): 45–50 Rc Suitable flux: SWX HF-N
Tube-Alloy A2JL-S	Modified stainless steel composition provides balanced characteristics, as well as good resistance to metal-to-metal wear, corrosion, and thermal fatigue cracking Typical applications: wide-body continuous caster rolls Typical hardness range (as deposited): 30–40 Rc Suitable flux: SWX HF-N
Tube-Alloy BU-S	Low-alloy steel deposit composition provides excellent compressive strength and machinability Typical applications: build-up on mild steel and low-alloy steel components Typical hardness range (as deposited): 20–30 Rc Suitable flux: SWX HF-N

SAW Approval Summary

Approvals									
SWX 110 flux	ABS	BV	DNV	GL	LR	CWB	DB	TüV	CE
With wire									
SDX S1-EL12									✓
SDX S2				4YM				✓	✓
SDX S2Si-EM12K	4Y400M	4Y40M	IVY40M	4YM	4Y40M	F49A4-EM12K	✓	✓	✓
SDX S2Mo-EA2		3YTM	IIITYM	3Y46T/4Y46M	3YTM	F8A6-EA2-A4		✓	✓
SDX S3Si-EH12K						F49A6-EH12K			✓
SDX S2Ni1Cu									✓
SubCOR™ EM13K-S MOD						F49A6-EC1			✓
SubCOR SL 731									✓
SubCOR SL 281 Cr									✓
SWX 120 flux	ABS	BV	DNV	GL	LR	CWB	DB	TüV	CE
SDX S2							✓	✓	✓
SDX S2Si-EM12K						F49A4-EM12K	✓	✓	✓
SDX S2Mo-EA2						F8A6-EA2-A4			✓
SDX S3Si-EH12K						F49A6-EH12K			✓
SubCOR EM13K-S MOD						F49A6-EC1			
SWX 130 flux	ABS	BV	DNV	GL	LR	CWB	DB	TüV	CE
SDX S2Mo-EA2									✓
SWX 135 flux	ABS	BV	DNV	GL	LR	CWB	DB	TüV	CE
SDX S2									✓
SDX S2Si-EM12K									✓
SDX S2Mo-EA2									✓
SWX 140 flux	ABS	BV	DNV	GL	LR	CWB	DB	TüV	CE
SDX S2				4YTM				✓	✓
SDX S2Si-EM12K									✓
SDX S2Mo-EA2	4Y 400 T		IV Y 40 T						✓
SubCOR SL 735 1W			III YTM	4YTM	3YM, 3YT				✓
SubCOR SL 735 2W+SDX S2			III YTM	4YTM	3YM, 3YT				✓
SubCOR SL 840 HC			3YM	6YM					✓
SWX 150 flux	ABS	BV	DNV	GL	LR	CWB	DB	TüV	CE
SDX EM13K	4YM								
SDX S2	3YM	A3YM	III YM	3YM	BF 3YM NR			✓	✓
SDX S2Si-EM12K					BF 5Y46M H5	F49A6-EM12K			✓
SDX S2Mo-EA2						F55A5-EA2-A2		✓	✓
SDX S3-EH10K								✓	
SDX S3Si-EH12K	5YQ460	A 5Y46M H5	V Y46(H5)	6Y46MH5	BF 5Y46M H5	F49A6-EH12K		✓	✓
SDX S2Ni2-ENi2									✓
SDX S3Ni1Mo-EF3	4YQ550M		IVY55M						✓
SDX S3Ni1Mo0.2-ENi5	4YQ460M		IVY46M						✓
SDX S3Ni2.5CrMo									✓
SubCOR EM13K-S	4YM								
SubCOR EM13K-S MOD	4YM								
SubCOR 120-S	F11A10-ECM4-M4								
SubCOR SL 731	3YM H5	3YM	III YM	3YM	5Y46M H5		✓	✓	✓
SubCOR SL 735 1W			III YTM	3YTM	3YM, 3YT				✓
SubCOR SL 735 2W+SDX S2	3YTM		III YTM	3YTM	3YM, 3YT				✓
SubCOR SL 741									✓
SubCOR SL 742	5YQ690M H5	A 5Y69M H5	V Y69MS H5	6Y69 H5	BF 5Y69M H5			✓	✓
<i>Note: SubCOR SL P1, P1 MOD, P11, P12, P22, P24, P36, and P5 are all CE approved.</i>									
SWX 220 flux	ABS	BV	DNV	GL	LR	CWB	DB	TüV	CE
SDX 2209									✓

SDX Solid Wire and Cromastrip Strip Range

			Chemical composition all weld metal, typical values (%)									
Non- and low-alloyed solid wires			C	Si	Mn	P	S	Cr	Ni	Mo	Cu	Other
Product name	EN ISO	AWS										
SDX S1-EL12	EN ISO 14171: S1	AWS A5.17: EL12	0.08	0.07	0.49	0.010	0.013	0.05	0.03	0.01	0.06	
SDX EM13K		AWS A5.17: EM13K	0.08	0.57	1.10	0.011	0.012	0.06	0.03	0.02	0.05	
SDX S2	EN ISO 14171: S2		0.10	0.11	0.97	0.010	0.011	0.05	0.05	0.02	0.04	
SDX S2Si-EM12K	EN ISO 14171: S2Si	AWS A5.17: EM12K	0.09	0.22	1.12	0.009	0.011	0.04	0.04	0.01	0.03	
SDX S2Mo-EA2	EN ISO 14171: S2Mo	AWS A5.23: EA2	0.09	0.12	1.09	0.010	0.012	0.05	0.04	0.50	0.04	
SDX S3-EH10K	EN ISO 14171: S3		0.11	0.12	1.55	0.010	0.009	0.04	0.03	0.01	0.05	
SDX S3Si-EH12K	EN ISO 14171: S3Si	AWS A5.17: EH12K	0.11	0.29	1.69	0.009	0.010	0.05	0.05	0.02	0.06	
SDX S3Mo-EA4	EN ISO 14171: S3Mo	AWS A5.23: EA4	0.12	0.10	1.45	0.010	0.012	0.04	0.03	0.52	0.05	
SDX S4-EH14	EN ISO 14171: S4	AWS A5.17: EH14	0.13	0.07	1.95	0.009	0.010	0.03	0.03	0.01	0.04	
SDX CrMo1-EB2R	EN ISO 24598: S CrMo1	AWS A5.23: EB2R	0.10	0.15	0.88	0.006	0.004	1.15	0.04	0.55	0.03	X<10
SDX CrMo2-EB3R	EN ISO 24598: S CrMo2	AWS A5.23: EB3R	0.11	0.14	0.60	0.004	0.005	2.45	0.05	1.02	0.04	X<10
SDX S2Ni1-ENi1	EN ISO 14171: S2Ni1	AWS A5.23: ENi1	0.09	0.12	0.96	0.009	0.007	0.04	0.97	0.02	0.05	
SDX S2Ni2-ENi2	EN ISO 14171: S2Ni2	AWS A5.23: ENi2	0.09	0.15	1.00	0.007	0.006	0.04	2.29	0.02	0.05	
SDX S2Ni1Cu	EN ISO 14171: S2Ni1Cu		0.10	0.22	0.99	0.010	0.009	0.25	0.79	0.02	0.49	
SDX S3Ni1Mo0.2-ENi5	EN ISO 14171: S3Ni1Mo0.2	AWS A5.23: ENi5	0.10	0.21	1.44	0.009	0.009	0.03	0.96	0.21	0.04	
SDX S3Ni1Mo-EF3	EN ISO 14171: S3Ni1Mo	AWS A5.23: EF3	0.12	0.11	1.72	0.010	0.008	0.03	0.92	0.55	0.05	
SDX S3Ni2.5CrMo	EN ISO 26304: S3Ni2.5CrMo		0.12	0.15	1.47	0.010	0.011	0.63	2.28	0.53	0.03	
SDX S3TiB			0.08	0.27	1.50	0.007	0.006	0.02	0.03	0.01	0.04	Ti 0.16. B 0.012
SDX S3MoTiB			0.07	0.25	1.30	0.009	0.007	0.03	0.03	0.53	0.05	Ti 0.15. B 0.013
Stainless solid wires			C	Si	Mn	P	S	Cr	Ni	Mo	N	Other
SDX 308L	EN ISO 14343: S 19 9 L	AWS A5.9: ER308L	0.02	0.48	1.80	0.012	0.010	20.2	10.3	0.2	0.04	
SDX 309L	EN ISO 14343: S 23 12 L	AWS A5.9: ER309L	0.01	0.45	1.85	0.016	0.012	23.7	12.9	0.1	0.06	
SDX 309LMo	EN ISO 14343: S 23 12 2 L		0.01	0.37	1.49	0.016	0.015	23.4	13.2	2.6	0.04	
SDX 316L	EN ISO 14343: S 19 12 3 L	AWS A5.9: ER316L	0.01	0.49	1.77	0.015	0.011	18.6	12.2	2.7	0.05	
SDX 317L	EN ISO 14343: S 19 13 4 L	AWS A5.9: ER317L	0.01	0.42	1.78	0.014	0.013	19.0	13.7	3.5	0.05	
SDX 347	EN ISO 14343: S 19 9 Nb	AWS A5.9: ER347	0.03	0.42	1.72	0.013	0.012	19.8	9.8	0.1	0.07	Nb 0.7
SDX 410NiMo		AWS A5.9: ER410NiMo	0.05	0.42	0.51	0.014	0.011	12.1	4.5	0.6	0.05	
SDX 2209	EN ISO 14343: S 22 9 3 N L	AWS A5.9: ER2209	0.01	0.48	1.50	0.016	0.010	22.9	8.3	3.2	0.15	
SDX 2594	EN ISO 14343: S 25 9 4 N L	AWS A5.9: ER2594	0.01	0.45	0.44	0.015	0.016	24.9	9.4	3.8	0.26	
Nickel-base solid wires			C	Si	Mn	P	S	Cr	Ni	Mo	N	Other
SDX NiCrMo-3	EN ISO 18274: S Ni6625	AWS A5.14: ERNiCrMo-3	0.06	0.22	0.27	0.014	0.013	21.9	63.8	9.1		Nb: 3.3 Fe: 1.1
SDX NiCr-3	EN ISO 18274: S Ni6082	AWS A5.14: ERNiCr-3	0.05	0.25	3.10	0.017	0.009	19.8	72.6	0.13		Nb: 2.8 Fe: 1.0
Stainless strips			C	Si	Mn	P	S	Cr	Ni	Mo	N	Other
For SAW												
Cromastrip 308L	EN ISO 14343: B 19 9 L	AWS A5.9: EQ308L	0.01	0.4	1.7	0.014	0.001	20.3	10.3	0.1	0.05	
Cromastrip 309L	EN ISO 14343: B 23 12 L	AWS A5.9: EQ309L	0.01	0.4	1.6	0.011	0.001	24.0	13.2	0.1	0.05	
Cromastrip 309LMo			0.01	0.3	1.7	0.015	0.001	20.2	14.3	2.8	0.04	
Cromastrip 309LNb	EN ISO 14343: B 23 12 L Nb		0.02	0.4	2.1	0.014	0.001	23.8	12.5	0.2	0.05	Nb 0.6
Cromastrip 316L	EN ISO 14343: B 19 12 3 L	AWS A5.9: EQ316L	0.02	0.4	1.6	0.020	0.001	18.3	12.6	2.8	0.05	
Cromastrip 347	EN ISO 14343: B 19 9 Nb	AWS A5.9: EQ347	0.02	0.4	1.7	0.014	0.001	19.7	10.5	0.1	0.05	Nb 0.5
For ESW												
Cromastrip 21.11 L	EN ISO 14343: B 21 11 L		0.02	0.3	1.7	0.014	0.001	21.2	11.2	0.1	0.03	
Cromastrip 21.13.3 L			0.01	0.4	1.7	0.017	0.001	20.3	14.3	2.8	0.04	
Cromastrip 21.11 LNb	EN ISO 14343: B 21 11 L Nb		0.01	0.3	1.7	0.015	0.001	21.3	11.1	0.1	0.05	Nb 0.6
Nickel-base strips			C	Si	Mn	P	S	Cr	Ni	Mo	N	Other
Cromastrip NiCrMo-3	EN ISO 18274: B Ni6625	AWS A5.14: ERNiCrMo-3	0.05	0.1	0.3	0.011	0.002	22.0	64.4	9.0	0.05	Nb 3.5 Fe 0.4
Cromastrip NiCr-3	EN ISO 18274: B Ni6082	AWS A5.14: ERNiCr-3	0.05	0.2	3.0	0.013	0.002	22.0	71.5	0.1	0.05	Nb 2.5 Fe 0.4

Flux Selection by ISO Classification

ISO spec	Wire/flux classification	Wire product name	Flux product name						
			SWX 110	SWX 120	SWX 130	SWX 135	SWX 140	SWX 150	SWX 160
Carbon steel solid wire electrodes									
14171-A	S 38 4 AB S2	SDX S2	✓		✓	✓			
14171-A	S 38 4 AB S2Si	SDX S2Si-EM12K			✓	✓			
14171-A	S 38 4 AB S3Si	SDX S2Si-EM12K	✓						
14171-A	S 38 5 AB S2	SDX S2		✓					
14171-A	S 38 5 AB S2Si	SDX S2Si-EM12K		✓					
14171-A	S 38 5 FB S2	SDX S2					✓		
14171-A	S 38 5 FB S2Si	SDX S2Si-EM12K					✓	✓	
14171-A	S 38 6 FB S3Si	SDX S3Si-EH12K							✓
14171-A	S 42 4 AB S3Si	SDX S3Si-EH12K	✓						
14171-A	S 46 6 AB S3Si	SDX S3Si-EH12K			✓				
14171-A	S 46 6 FB S3Si	SDX S3Si-EH12K						✓	
14171-A	S 50 4 FB S4	SDX S4-EH14						✓	
14171-B	S 3T 2 AB S3Si	SDX S3Si-EH12K	✓						
Carbon steel composite electrodes									
14171-A	S 46 4 AB T3	SubCOR™ SL 731	✓	✓					
14171-A	S 46 6 FB T3	SubCOR SL 731						✓	
14171-A	S 46 6 FB T3Ni1	SubCOR SL 840 HC					✓		
14171-B	S55A6U FB TU3M	SubCOR SL 731						✓	
14171-B	S55P6 FB TUN2	SubCOR SL 840 HC					✓		
Low-alloy solid wire electrodes									
14171-A	S 42 4 FB S2Ni1	SDX S2Ni1-ENi1						✓	
14171-A	S 46 2 AB S2Mo	SDX S2Mo-EA2			✓	✓			
14171-A	S 46 3 AB S2Ni1Cu	SDX S2Ni1Cu	✓						
14171-A	S 46 4 AB S2Mo	SDX S2Mo-EA2		✓					
14171-A	S 46 4 FB S2Mo	SDX S2Mo-EA2					✓		
14171-A	S 46 4 FB S3Si	SDX S2Mo-EA2						✓	
14171-A	S 46 6 FB S2Ni1Mo0.2	SDX S3Ni1Mo0.2-ENi5						✓	
14171-A	S 46 7 FB S2Ni2	SDX S2Ni2-ENi2						✓	
14171-A	S 50 2 AB S3Mo	SDX S3Mo-EA4			✓	✓			
14171-A	S 50 4 AB S3Ni1Mo0.2	SDX S3Ni1Mo0.2-ENi5	✓						
14171-A	S 62 6 FB S3Ni1Mo	SDX S3NiMo-EF3						✓	
14171-B	S 4T 3 AB S2Mo	SDX S2Mo-EA2		✓					
26304-A	S 69 6 FB S3Ni2.5CrMo	SDX S3Ni2.5CrMo						✓	
26304-A	S 79 6 FB S3Ni2.5CrMo	SDX S3Ni2.5CrMo							✓
24598-A	S S CrMo1 FB	SDX CrMo1-EB2R						✓	✓
24598-A	S S CrMo2 FB	SDX CrMo2-EB3R						✓	✓

Flux Selection by ISO Classification

ISO spec	Wire/flux classification	Wire product name	Flux product name						
			SWX 110	SWX 120	SWX 130	SWX 135	SWX 140	SWX 150	SWX 160
Low-alloy composite electrodes									
14171-A	S 46 4 AB TZ	SubCOR™ SL 281 Cr	✓						
14171-A	S 46 4 FB T3	SubCOR SL 735 1W-5W					✓		
14171-B	S55A4U FB TUZ	SubCOR SL 281 Cr						✓	
24598-A	ST CrMo1 FB	SubCOR SL P11					✓		
24598-A	ST CrMo1 FB	SubCOR SL P91							✓
24598-A	ST CrMo2 FB	SubCOR SL P22					✓		
24598-A	ST CrMo5 FB	SubCOR SL P5					✓		
24598-A	ST CrMo9 FB	SubCOR SL P9					✓		
24598-A	ST CrMo 91 FB	SubCOR SL P91					✓		
24598-A	ST CrMoWV12 FB	SubCOR SL P92					✓		
24598-A	ST Mo FB	SubCOR SL P1					✓		
24598-A	ST MoV FB	SubCOR SL P1 MOD					✓		
24598-B	S 49 2 FB TU G	SubCOR SL P1 MOD					✓		
24598-B	S 55 0 FB TU (9C1M)	SubCOR SL P9					✓		
24598-B	S 55 2 FB TU 2C1MV	SubCOR P24					✓		
24598-B	S 55 4 FB TU 1CM	SubCOR SL P11					✓		
24598-B	S 55 4 FB TU 1M3	SubCOR SL P1					✓		
24598-B	S 55 4 FB TU 5CM	SubCOR SL P5					✓		
24598-B	S 62 0 FB TU 9C1MV1	SubCOR SL P91					✓		
24598-B	S 62 2 FB TU 2C1M	SubCOR SL P22					✓		
24598-B	S 62 4 FB TU G	SubCOR SL P36					✓		
24598-B	S 62 Y FB TUG (CrMoV1)	SubCOR SL P12 MOD					✓		
26304-A	S 55 6 FB T3 Ni1Mo	SubCOR SL 741					✓		
26304-A	S 69 6 FB T3 Ni2.5CrMo	SubCOR SL 742					✓		✓
26304-A	S 89 4 FB T3Ni2.5Cr1Mo	SubCOR SL 745					✓		
26304-B	S 69A6 FB TUN2M2	SubCOR SL 741					✓		
26304-B	S76A6 FB TUN5CM3	SubCOR SL 742					✓		
26304-B	S83A 4 FB TU G	SubCOR SL 745					✓		

Flux Selection by AWS Wire Classification

Alloy	Wire/flux classification	Wire product name	Flux product name						
			SWX 110	SWX 120	SWX 130	SWX 135	SWX 140	SWX 150	SWX 160
Carbon steel solid wire electrodes — AWS A5.17									
	F7A4-EM12K	SDX S2Si-EM12K	✓		✓	✓			
	F7A4-EM13K	SDX EM13K	✓					✓	✓
	F7A6-EM12K	SDX S2Si-EM12K		✓				✓	✓
	F7A6-EH12K	SDX S3Si-EH12K	✓		✓				
	F7P6-EH12K	SDX S3Si-EH12K	✓						
	F7A8-EH12K	SDX S3Si-EH12K							✓
	F7P8-EH12K	SDX S3Si-EH12K						✓	✓
Carbon steel composite electrodes — AWS A5.17									
	F6P8-EC1	SubCOR™ EM13K-S		✓				✓	✓
	F7A4-EC1	SubCOR EM12K-S	✓			✓			✓
	F7A6-EC1	SubCOR EM12K-S		✓				✓	
	F7A6-EC1	SubCOR EM13K-S	✓		✓	✓			
	F7A6-EC1	SubCOR EM13K-S MOD	✓		✓	✓			
	F7P6-EC1	SubCOR EM13K-S	✓		✓	✓			
	F7P6-EC1	SubCOR EM13K-S MOD	✓						
	F7A8-EC1	SubCOR EM13K-S		✓				✓	✓
	F7A8-EC1	SubCOR EM13K-S MOD		✓					✓
	F7P8-EC1	SubCOR EM13K-S MOD		✓	✓	✓		✓	✓
	F7A10-EC1	SubCOR EM13K-S MOD					✓		
Low-alloy solid wire electrodes — AWS A5.23									
A2	F7A4-EA2-A4	SDX S2Mo-EA2	✓		✓	✓			
	F7P4-EA2-A4	SDX S2Mo-EA2	✓		✓	✓			
	F7A6-EA2-A4	SDX S2Mo-EA2		✓				✓	
	F7A6-EA2-A2	SDX S2Mo-EA2							✓
	F7P6-EA2-A4	SDX S2Mo-EA2		✓				✓	
	F7P6-EA2-A2	SDX S2Mo-EA2							✓
Ni	F7A8-ENi1-Ni1	SDX S2Ni1-ENi1							✓
	F7P8-ENi1-Ni1	SDX S2Ni1-ENi1							✓
	F8A6-ENi5-Ni5	SDX S3Ni1Mo0.2-ENi5	✓						
	F8P6-ENi5-Ni5	SDX S3Ni1Mo0.2-ENi5							✓
	F8A8-ENi5-Ni5	SDX S3Ni1Mo0.2-ENi5							✓
	F8A10-ENi2-Ni2	SDX S2Ni2-ENi2							✓
B	F8P10-ENi2-Ni2	SDX S2Ni2-ENi2							✓
	F8P0-EB3R-B3	SDX CrMo2-EB3R							✓
	F8P2-EB3R-B3R	SDX CrMo2-EB3R							✓
	F8P2-EB2R-B2	SDX CrMo1-EB2R						✓	
F	F8P2-EB2R-B2R	SDX CrMo1-EB2R							✓
	F10A8-EF3-F3	SDX S3Ni1Mo-EF3						✓	
Low-alloy composite electrodes — AWS A5.23									
W	F7A6-ECW-W	SubCOR W-S							✓
Ni	F7A8-ECNi1-Ni1	SubCOR N1-S							✓
	F7P10-ECNi1-Ni1	SubCOR N1-S							✓
M1	F8P8-ECM1-M1	SubCOR 92-S		✓				✓	✓
	F8A10-ECM1-M1	SubCOR 92-S		✓				✓	✓
B	F9P2-ECB2-B2	SubCOR B2-S							✓
	F9P3-ECB3-B3	SubCOR B3-S							✓
F	F10P8-ECF3-F3	SubCOR 100F3-S						✓	
	F10A10-ECF3-F3	SubCOR 100F3-S						✓	✓
	F10P10-ECF3-F3	SubCOR 100F3-S							✓
	F10A10-ECF2-F2	SubCOR F2-S							✓
	F10P10-ECF2-F2	SubCOR F2-S							✓
	F11A8-ECF5-F5	SubCOR SL 742							
M4	F11A6-ECM4-M4	SubCOR 120-S							✓
	F11A10-ECM4-M4	SubCOR 120-S						✓	

Flux Selection by SDX Solid Wire

SDX solid wire	SWX 110	SWX 120	SWX 130	SWX 135	SWX 140	SWX 150	SWX 160
SDX S2Si-EM12K	F7A4-EM12K	F7A6-EM12K	F7A4-EM12K	F7A4-EM12K	F7A6-EM12K	F7A6-EM12K	
SDX EM13K-S	F7A4-EM13K	F7A4-EM13K			F7A4-EM13K	F7A4-EM13K	
SDX S3Si-EH12K	F7A6-EH12K		F7A6-EH12K			F7A8-EH12K	
SDX S3Si-EH12K	F7P6-EH12K					F7P8-EH12K	F7P8-EH12K
SDX S2Mo-EA2	F7A4-EA2-A4	F7A6-EA2-A4	F7A4-EA2-A4	F7A4-EA2-A4	F7A6-EA2-A4	F7A6-EA2-A2	
SDX S2Mo-EA2	F7P4-EA2-A4	F7P6-EA2-A4	F7P4-EA2-A4	F7P4-EA2-A4	F7P6-EA2-A4	F7P6-EA2-A2	
SDX CrMo1-EB2R						F8P2-EB2R-B2	F8P2-EB2R-B2R
SDX CrMo2-EB3R						F8P0-EB3R-B3	F8P2-EB3R-B3R
SDX S2Ni1-ENi1						F7A8-ENi1-N1	
SDX S2Ni1-ENi1						F7P8-ENi1-N1	
SDX S2Ni2-ENi2						F8A10-ENi2-Ni2	
SDX S2Ni2-ENi2						F8P10-ENi2-Ni2	
SDX S3Ni1Mo0.2-ENi5	F8A6-ENi5-Ni5					F8A8-ENi5-Ni5	
SDX S3Ni1Mo0.2-ENi5						F8P6-ENi5-Ni5	
SDX S3Ni1Mo-EF3						F10A8-EF3-F3	

Flux Selection by SubCOR™ Cored Wire

SubCOR cored wire	SWX 110	SWX 120	SWX 130	SWX 135	SWX 140	SWX 150	SWX 160
SubCOR EM12K-S	F7A4-EC1	F7A6-EC1	F7A6-EC1	F7A4-EC1	F7A6-EC1	F7A4-EC1	
SubCOR EM13K-S	F7A6-EC1	F7A8-EC1	F7A6-EC1	F7A6-EC1	F7A8-EC1	F7A8-EC1	
SubCOR EM13K-S	F7P6-EC1	F6P8-EC1	F7P6-EC1	F7P6-EC1		F6P8-EC1	
SubCOR EM13K-S MOD	F7A6-EC1	F7A8-EC1	F7A6-EC1	F7A6-EC1	F7A10-EC1	F7A8-EC1	
SubCOR EM13K-S MOD	F7P6-EC1	F7P8-EC1	F7P8-EC1	F7P8-EC1	F7P8-EC1	F7P8-EC1	
SubCOR B2-S						F9P2-ECB2-B2	
SubCOR B3-S						F9P2-ECB3-B3	
SubCOR 92-S		F8A10-ECM1-M1			F8A10-ECM1-M1	F8A10-ECM1-M1	
SubCOR 92-S		F8P8-ECM1-M1			F8P8-ECM1-M1	F8P8-ECM1-M1	
SubCOR F2-S						F10A10-ECF2-F2	
SubCOR F2-S						F10P10-ECF2-F2	
SubCOR 100F3-S					F10A10-ECF3-F3	F10A10-ECF3-F3	
SubCOR 100F3-S					F10P8-ECF3-F3	F10P10-ECF3-F3	
SubCOR 120-S						F11A10-ECM4-M4	F11A6-ECM4-M4
SubCOR Ni1-S						F7A8-ECNi1-Ni1	
SubCOR Ni1-S						F7P10-ECNi1-Ni1	
SubCOR SL 742						F11A8-ECF5-F5	F11A8-ECF5-F5
SubCOR W-S						F7A6-ECW	

SWX 110

EN ISO 14174: S A AB 1 67 AC H5

Flux/wire combinations for the Submerged Arc welding of non- and low-alloyed steels

Description

Hobart SWX 110 is a versatile and universally applied agglomerated welding flux. It has a carefully chosen aluminate-basic formulation — with a basicity between neutral and basic — providing a set of welding characteristics that makes the flux suited for a wide range of Submerged Arc welding applications in a variety of industries. It combines high travel speeds and excellent slag detachability with good low-temperature impact toughness down to -40°C (-40°F). Suited for single- and multi-run welding with smooth weld bead appearance and self detaching slag. It has a wide parameter box and performs equally well in single-wire, twin-wire and tandem welding, making it the perfect choice for productive welding of heavy sections. All of this makes SWX 110 an excellent multi-application

flux on the shop floor. SWX 110 can be used with a range of wires to cover mild steel and medium-tensile fine-grained steel. SWX 110 is applied in general construction, machine and heavy equipment building, pressure vessel fabrication, shipbuilding and water and sewage pipes. Typical shipbuilding applications are the single- or double-sided welding of ship panels. Use of the flux in combination with Hobart cored wires offers further opportunities to improve weld metal quality, making use of unique cored wire properties.

The flux is delivered in Hobart humidity-proof packaging — EAE bag or DoubleBag™ — eliminating the need to re-dry the flux.

- General construction
- Double jointing
- Heavy equipment
- Bridge building
- Shipbuilding
- Pressure vessels
- Heavy beams
- Tank building
- Water and sewage pipes

Flux characteristics

Flux type	Aluminate-basic
Basicity index	1.4 (Boniszewski)
Alloy transfer	Slightly Si and Mn alloying
Density	1.2 kg/liter
Grain size	0.2–2.0 mm /10–70 mesh
HDM	< 5 ml/100 g weld metal
Current	DC+/AC
Re-drying unopened bag	Not required
Re-drying opened bag	See storage and handling recommendations

Flux main components

Al ₂ O ₃ + MnO	CaO + MgO	SiO ₂ + TiO ₂	CaF ₂
~35%	~25%	~20%	~15%

Metallurgical behavior

The diagrams show the typical weld metal analysis in relation to wire analysis for silicon and manganese.

Single wire, ø 4.0 mm (5/32"), DC+, 30 V, 60 cm/min (24"/min)

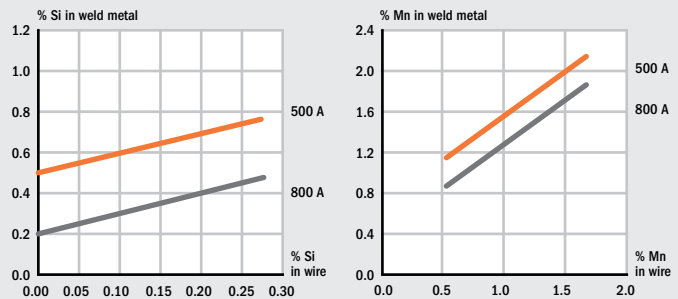

Flux SWX 110 — Classifications

Mechanical properties*

With wire	EN ISO	AWS	Mechanical properties*							YS ksi	TS ksi	E %	CVN ft-lbf				
			Re/Rp0.2 MPa	Rm MPa	A %	CVN J	0°C	-20°C	-30°C					-40°C	-46°C	0°F	-20°F
SDX EM13K	AW	A5.17: F7A4-EM13K								75	87	28			22		
SDX S2	AW 14171-A: S 38 4 AB S2		420	500	26	130	110	65									
SDX S2Si-EM12K	AW 14171-A: S 38 4 AB S2Si	A5.17: F7A5-EM12K	420	500	26	130	100	60		71	83	29		48	35		
SDX S3Si-EH12K**	AW 14171-A: S 42 4 AB S3Si	A5.17: F7A6-EH12K	450	560	28		110	65	50	76	88	27			54	38	
	SR ¹	A5.17: F7P6-EH12K	440	550	28		100	55	40	67	83	28				58	29
SDX S2Mo-EA2	AW 14171-A: S 46 2 AB S2Mo	A5.23: F7A4-EA2-A4	510	590	24	90	70	50		80	90	26		58	33		
	SR ¹	A5.23: F7P4-EA2-A4	470	560	24	70	40		74	86	27		49	33			
	TR 14171-A: S 4T 2 AB S2Mo						50										
SDX S3Ni1Mo0.2-ENi5	AW 14171-A: S 50 4 AB S3Ni1Mo0.2	A5.23: F8A6-ENi5-Ni5	570	640	24	90	75	65	40	88	97	25		63	37		
SDX S2Ni1Cu	AW 14171-A: S 46 3 AB S2Ni1Cu		485	570	26		70	55									
SubCOR™ EM12K-S	AW	A5.17: F7A4-EC1								60	71	30		45			
SubCOR EM13K-S	AW	A5.17: F7A6-EC1								64	73	28			97	75	
	SR ¹	A5.17: F7P6-EC1								64	77	32			264	127	
SubCOR EM13K-S MOD	AW	A5.17: F7A6-EC1								76	84	29				115	50
	SR ¹	A5.17: F7P6-EC1								68	80	31		143		105	
SubCOR SL 731	AW 14171-A: S 46 4 AB T3		490	600	29		150	115									
	SR ¹		490	600	29		150	115									
SubCOR SL 281 Cr	AW 14171-A: S 46 4 AB TZ		490	590	25		100	80									

AW: as welded, all weld metal. SR: stress relieved, all weld metal. TR: two-run. SR¹: PWHT 1150°F (620°C) / 1 h.

*Metric values are typical of EN ISO testing and imperial values are typical of AWS testing. **Use with precaution. In certain applications, the manganese content may reach critical levels, leading to hot cracking.

SWX 110 (continued)

EN ISO 14174: S A AB 1 67 AC H5

Flux/wire combinations for the Submerged Arc welding of non- and low-alloyed steels

Flux SWX 110 — Chemical composition all weld metal, typical values

With wire	%C	%Si	%Mn	%Cr	%Ni	%Mo	%Cu
SDX EM13K	0.06	0.3	1.2				
SDX S2	0.06	0.3	1.2				
SDX S2Si-EM12K	0.06	0.5	1.3				
SDX S2Mo-EA2	0.06	0.3	1.3			0.5	
SDX S3Si-EH12K	0.07	0.5	1.9				
SDX S3Ni1Mo0.2-ENi5	0.09	0.25	1.4		0.9	0.2	
SDX S2Ni1Cu	0.08	0.4	1.3		0.7		0.5
SubCOR™ EM12K-S	0.05	0.2	1.2				
SubCOR EM13K-S	0.06	0.3	1.2				
SubCOR EM13K-S MOD	0.07	0.4	1.3				
SubCOR SL 731	0.05	0.3	2.1				
SubCOR SL 281 Cr	0.12	0.6	1.3	0.5	0.6		0.5

Materials to be welded

Steel group	Typical examples of steel types	Impact requirement ≥47 J (≥20 ft-lbf)	Flux SWX 110 with wire
Normal-strength steel			
Rel ≤ 355 MPa	S235JR, S275JR, A106 Gr. B, A333 Gr. 6, P235GH, S275JO, P295GH	-20°C	SDX S2
		-40°C	SDX S2, SDX S2Si-EM12K
Rel ≥ 355 MPa	S420N, S460ML, P420ML2, S420MCD, S420G2+M, X60, L450	-20°C	SDX S2Mo-EA2
		-40°C	SDX S2, SDX S2Si-EM12K,
TS > 58 ksi	A36, A709 Gr. 36,	-40°F	SubCOR™ EM12K-S
		-100°F	SubCOR EM13K-S, SubCOR EM13K-S MOD
TS > 65 ksi	A572 Gr.50, A709 Gr. 50, A709 Gr. 50S, A992	-40°F	SubCOR EM12K-S
		-100°F	SubCOR EM13K-S, SubCOR EM13K-S MOD
TS > 70 ksi	A588, A516 Gr.70	-40°F	SubCOR EM12K-S
		-100°F	SubCOR EM13K-S, SubCOR EM13K-S MOD
High-strength steel			
Rel ≥ 420 MPa	S420N, S460ML, P420ML2, S420MCD, S420G2+M, X60, L450	-20°C	SDX S2Mo-EA2, SDX S2Mo-EA2
		-40°C	SDX S3Si-EH12K, SubCOR SL 731
Rel ≥ 460 MPa	S460M, S460ML, S460ML2, S460MCD, S460G2+M, X65, L450	-20°C	SDX S2Mo-EA2
		-40°C	SubCOR SL 731
Rel ≥ 500 MPa	S500QL, S500QL1, P500QL1, P500QL2, X70, S500G2+M	-40°C	SDX S3Ni1Mo0.2-ENi5
Shipbuilding steel			
	A to D, AH36 to EH36	-20°C	SDX S2Mo-EA2
		-40°C	SDX S2, SDX S2Si-EM12K
			SDX S3Si-EH12K, SubCOR SL 731
Weather-resistant steel			
Rel ≤ 355	S235JOW, S355J2WP, S355J2G2W, COR-TEN, A242-type1, A588	-20°C	SDX S2Ni1Cu, SubCOR SL 281 Cr

Approvals

With wire	ABS	BV	DNV	GL	LR	CWB	DB	TÜV	CE
SDX S1-EL12									✓
SDX S2				4YM				✓	✓
SDX S2Si-EM12K	4Y400M	4Y40M	IVY40M	4YM	4Y40M	F49A4-EM12K	✓	✓	✓
SDX S2Mo-EA2		3YTM	IIITYM	3Y46T/4Y46M	3YTM	F8A6-EA2-A4		✓	✓
SDX S3Si-EH12K						F49A6-EH12K			✓
SDX S2Ni1Cu									✓
SubCOR™ EM13K-S MOD						F49A6-EC1			✓
SubCOR SL 731									✓
SubCOR SL 281 Cr									✓

SWX 120

EN ISO 14174: S A AB 1 57 AC H5

Flux/wire combinations for the Submerged Arc welding of non- and low-alloyed steels

Description

Hobart SWX 120 is specifically designed for the wind tower manufacturing industry where high-integrity longitudinal and circumferential welds are the challenge and productive welding a prerequisite. The formulation of this aluminate-basic flux has been adapted towards a higher basicity while maintaining the good welding characteristics of a lower basicity flux. The result is a “production” flux that yields remarkably good low-temperature impact toughness down to -50°C (-58°F), using SDX S2 or SDX S2Si-EM12K welding wires. This flux guarantees uniform chemistry and mechanical properties throughout the heavy, multi-layer welds that are familiar to this industry. SWX 120 has a high current carrying capacity and allows high travel speeds. The slag is easily removed from the

first layers in commonly applied narrow Y-joints and self-detaching in subsequent filler and capping layers. Very well suited for single-wire, twin-wire, tandem and tandem twin-wire welding, offering higher welding productivity and increased efficiency. Other industries with similar requirements, such as pressure vessel fabrication and general construction, will benefit equally well from this outstanding welding flux. Use of the flux in combination with Hobart cored wires offers further opportunities to improve weld metal quality, making use of unique cored wire properties.

The flux is delivered in Hobart humidity-proof packaging — EAE bag or DoubleBag™ — eliminating the need to re-dry the flux.

- Wind towers
- Pressure vessels
- General construction
- Tank building

Flux characteristics

Flux type	Aluminate-basic
Basicity index	1.9 (Boniszewski)
Alloy transfer	Slightly Mn alloying
Density	~1.2 kg/liter
Grain size	0.2–2.0 mm /10–70 mesh
HDM	< 5 ml/100 g weld metal
Current	DC+/AC
Re-drying unopened bag	Not required
Re-drying opened bag	See storage and handling recommendations

Flux main components

Al ₂ O ₃ + MnO	CaO + MgO	SiO ₂ + TiO ₂	CaF ₂
~35%	~25%	~20%	~20%

Metallurgical behavior

The diagrams show the typical weld metal analysis in relation to wire analysis for silicon and manganese.

Single wire, ø 4.0 mm (5/32”), DC+, 30 V, 60 cm/min (24”/min)

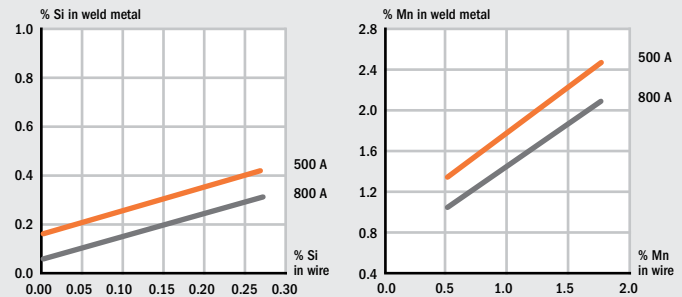

Flux SWX 120 — Classifications

Mechanical properties*

With wire	EN ISO	AWS	Re/Rp0.2				A	CVN				YS	TS	E	CVN
			MPa	MPa	%	J		ksi	ksi	%	ft-lbf				
			-20°C -40°C -50°C -60°C								0°F -20°F -40°F -60°F -80°F -100°F				
SDX EM13K	AW	A5.17: F7A4-EM13K									77	87	29		40
SDX S2	AW	14171-A: S 38 5 AB S2	420	500	26	120	95	70	45						
SDX S2Si-EM12K	AW	14171-A: S 38 5 AB S2Si	A5.17: F7A6-EM12K	430	510	26	130	100	75	45	66	78	27		76 68
SDX S2Mo-EA2	AW	14171-A: S 46 4 AB S2Mo	A5.23: F7A6-EA2-A4	500	590	24	90	60			73	83	25		69
	SR ¹		A5.23: F7P6-EA2-A4	490	575	24	90	60	45		68	91	29		44 30
	TR	14171-A: S 4T 3 AB S2Mo					65	40							
SDX S3Si-EH12K**	AW	14171-A: S 46 4 AB S3Si		490	580	27	120	80	50						
	SR ¹			480	570	27	110	70	45						
	TR	14171-A: S 3T 2 AB S3Si					55	30							29
SubCOR™ EM12K-S	AW		A5.17: F7A6-EC1								60	70	32		110
SubCOR EM13K-S	AW		A5.17: F7A8-EC1								58	71	29		105
	SR ¹		A5.17: F6P8-EC1								51	66	34		143 142
SubCOR EM13K-S MOD	AW		A5.17: F7A10-EC1								72	82	29		161 105
	SR ¹		A5.17: F7P8-EC1								67	80	29	221	134
SubCOR 92-S	AW		A5.23: F8A10-ECM1-M1								79	93	26		85 52
	SR ¹		A5.23: F8P8-ECM1-M1								71	84	27	103	77
SubCOR SL 731	AW	14171-A: S 46 4 AB T3	A5.23: F8A4-ECG	500	600	27	145	125	54		111	121	22		55 48
	SR ¹			480	580	26	140	120	50						

AW: as welded, all weld metal. SR: stress relieved, all weld metal. TR: two-run. SR¹: 1150°F (620°C) / 1 h. SR²: 1125°F (605°C) / 1 h.

*Metric values are typical of EN ISO testing and imperial values are typical of AWS testing. **Use with precaution. In certain applications, the manganese content may reach critical levels, leading to hot cracking.

SWX 120 (continued)

EN ISO 14174: S A AB 1 57 AC H5

Flux/wire combinations for the Submerged Arc welding of non- and low-alloyed steels

Flux SWX 120 — Chemical composition all weld metal, typical values

With wire	%C	%Si	%Mn	%Ni	%Mo
SDX EM13K	0.05	0.2	1.2		
SDX S2	0.07	0.2	1.4		
SDX S2Si-EM12K	0.07	0.3	1.4		
SDX S2Mo-EA2	0.07	0.2	1.4		0.5
SDX S3Si-EH12K	0.10	0.2	2.0		
SubCOR™ EM12K-S	0.05	0.2	1.2		
SubCOR EM13K-S	0.05	0.2	1.2		
SubCOR EM13K-S MOD	0.08	0.3	1.2		
SubCOR 92-S	0.08	0.2	1.3	1.6	0.2
SubCOR SL 731	0.06	0.5	2.1		

Materials to be welded

Steel group	Typical examples of steel types	Impact requirement ≥47 J (≥20 ft-lbf)	Flux SWX 120 with wire
Normal-strength steel			
Rel ≤ 355 MPa	S235JR, A106 Gr. B, A333 Gr. 6, P235GH, S275J0, S275JR, P295GH	-30°C	SDX S2Mo-EA2
		-50°C	SDX S2, SDX S2Si-EM12K
Rel ≥ 355 MPa	S355J2, S355N, P355NL1, L360, S355MCD, S355ML, P355GH	-20°C	SDX S3Si-EH12K
		-30°C	SDX S2Mo-EA2
		-50°C	SDX S2, SDX S2Si-EM12K
TS > 58 ksi	A36, A709 Gr. 36	-60°F	SubCOR™ EM12K-S
		-80°F	SubCOR EM13K-S
		-100°F	SubCOR EM13K-S MOD
TS > 65 ksi	A572 Gr. 50, A709 Gr. 50, A709 Gr. 50S, A992	-60°F	SubCOR EM12K-S
		-80°F	SubCOR EM13K-S
		-100°F	SubCOR EM13K-S MOD
High-strength steel			
Rel ≥ 420 MPa	S420N, S460ML, P420ML2, S420MCD, S420G2+M, L450	-30°C	SDX S2Mo-EA2
		-40°C	SDX S3Si-EH12, SubCOR SL 731
Rel ≥ 460 MPa	S460M, S460ML, S460ML2, S460MCD, S460G2+M, L450	-30°C	SDX S2Mo-EA2
		-40°C	SDX S3Si-EH12, SubCOR SL 731
TS > 70 ksi	A588, A516 Gr. 70	-60°F	SubCOR EM12K-S
		-80°F	SubCOR EM13K-S
		-100°F	SubCOR EM13K-S MOD
Creep-resistant steel			
0.5% Mo	P295GH, P355GH, 16Mo3, 17Mo3, 14Mo6	-30°C	SDX S2Mo-EA1

Approvals

With wire	CWB	DB	TÜV	CE
SDX S2		✓	✓	✓
SDX S2Si-EM12K	F49A4-EM12K	✓	✓	✓
SDX S2Mo-EA2	F8A6-EA2-A4			✓
SDX S3Si-EH12K	F49A6-EH12K			✓
SubCOR™ EM13K-S MOD	F49A6-EC1			

SWX 130

EN ISO 14174: S A AB 1 67 AC H5

Flux/wire combinations for the Submerged Arc welding of non- and low-alloyed steels

Description

Hobart SWX 130 is the welding flux that answers the call from longitudinal pipe mill manufacturers for increased welding speed and good mechanical properties in two-run welding. Thanks to its high current carrying capacity, it is very well suited for multi-wire welding with up to five wires. At high welding speeds, it produces the desired flat and wide bead profile with absence of peaks, which provides savings in pipe coating operations.

Slag is self-detaching. With the right combination of wires, steel grades up to X100 can be welded with matching mechanical properties.

The flux is delivered in Hobart humidity-proof packaging — EAE bag or DoubleBag™ — eliminating the need to re-dry the flux.

- Longitudinal pipe mills

Flux characteristics

Flux type	Aluminate-basic
Basicity index	1.5 (Boniszewski)
Alloy transfer	Slightly Si and Mn alloying
Density	1.2 kg/liter
Grain size	0.2–2.0 mm /10–70 mesh
HDM	< 5 ml/100 g weld metal
Current	DC+/AC
Re-drying unopened bag	Not required
Re-drying opened bag	See storage and handling recommendations

Flux main components

AL ₂ O ₃ + MnO	CaO + MgO	SiO ₂ + TiO ₂	CaF ₂
~30%	~25%	~20%	~15%

Metallurgical behavior

The diagrams show the typical weld metal analysis in relation to wire analysis for silicon and manganese.

Single wire, ø 4.0 mm (5/32"), DC+, 30 V, 60 cm/min (24"/min)

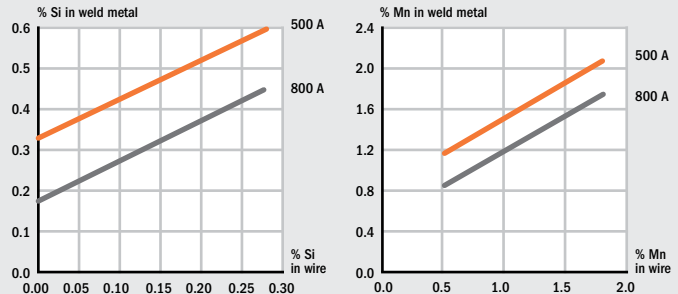

Flux SWX 130 — Classifications

With wire	EN ISO	AWS	Mechanical properties *							YS ksi	TS ksi	E %	CVN ft-lbf				
			Re/Rp0.2 MPa	Rm MPa	A %	CVN J	0°C	-20°C	-30°C					-40°C	-50°C	0°F	-20°F
SDX S2	AW 14171-A: S 38 4 AB S2		430	520	27	110	75	60									
SDX S2Si-EM12K	AW 14171-A: S 38 4 AB S2Si	A5.17: F7A4-EM12K	430	520	27	100	70	50	69	82	27	23					
SDX S3Si-EH12K	AW 14171-A: S 46 6 AB S3Si	A5.17: F7A6-EH12K	490	550	29				81	91	27	46					
SDX S2Mo-EA2	AW 14171-A: S 46 2 AB S2Mo	A5.23: F7A4-EA2-A4	520	590	24	100	70	40	80	90	27	39					
	SR ¹	A5.23: F7P4-EA2-A4							76	88	28	32					
SDX S3Mo-EA4	AW 14171-A: S 50 2 AB S3Mo		580	670	23		55	40									
SubCOR™ EM12K-S	AW	A5.17: F7A6-EC1							60	71	29	84					
SubCOR EM13K-S	AW	A5.17: F7A6-EC1							65	77	31	70	53				
	SR ¹	A5.17: F7P6-EC1							58	72	33	84	69				
SubCOR EM13K-S MOD	AW	A5.17: F7A6-EC1							77	87	27	50					
	SR ¹	A5.17: F7P8-EC1							68	83	29	102	47				

Mechanical properties of two-run pipe joint (high dilution)

SDX S2Mo-EA2	TR		480	550	23	100	80	50									
SDX S3Mo-EA4	TR		510	590	20	70											
SDX S3TiB	TR		560	700	20		45										
SDX S3MoTiB	TR		630	700	25	200	180	120									
SubCOR SL 735-1W-5W**	TR		480	600	24	60	50										

Mechanical properties of pipe welds in the two-run technique depend on the chemical composition of the base material.

AW: as welded, all weld metal. SR: stress relieved, all weld metal. TR: two-run. SR¹: PWHT 1150°F (620°C) / 1 h.

*Metric values are typical of EN ISO testing and imperial values are typical of AWS testing. **Depends on the type of solid wire used.

SWX 130 (continued)

EN ISO 14174: S A AB 1 67 AC H5

Flux/wire combinations for the Submerged Arc welding of non- and low-alloyed steels

Flux SWX 130 — Chemical composition all weld metal, typical values

With wire	%C	%Si	%Mn	%Mo	%Ti	%B
SDX S2	0.06	0.2	1.3			
SDX S2Si-EM12K	0.06	0.3	1.3			
SDX S3Si-EH12K	0.08	0.3	1.6			
SDX S2Mo-EA2	0.05	0.4	1.4	0.5		
SDX S3Mo-EA4	0.08	0.4	1.6	0.5		
SubCOR™ EM12K-S	0.05	0.2	1.2			
SubCOR EM13K-S	0.06	0.4	1.2			
SubCOR EM13K-S MOD	0.06	0.4	1.1			
Weld metal analyses of two-run pipe joint (high dilution)						
SDX S3TiB	0.06	0.5	1.6		0.024	0.0024
SDX S3MoTiB	0.06	0.5	1.4	0.3	0.022	0.0024
SubCOR SL 735-1W-5W	Depends on the type of solid wire used.					

Materials to be welded

Steel group	Typical examples of steel types	Impact requirement ≥47 J (≥20 ft-lbf)	Flux SWX 130 with wire
Normal-strength steel			
Rel ≤ 355 MPa	X42, X46, L235, L265, L295, L320	-40°C	SDX S2Mo-EA2
		-50°C	SDX S3MoTiB
Rel ≥ 355 MPa	X52, L355, L360, L385L, 390, L415	-40°C	SDX S2Mo-EA2
		-50°C	SDX S3MoTiB
TS > 58 ksi	A36, A709 Gr. 36,	-60°F	SubCOR™ EM12K-S
		-80°F	SubCOR EM13K-S, SubCOR EM13K-S MOD
TS > 65 ksi	A572 Gr. 50, A709 Gr. 50, A709 Gr. 50S, A992	-60°F	SubCOR EM12K-S
		-80°F	SubCOR EM13K-S, SubCOR EM13K-S MOD
High-strength steel			
Rel ≥ 420 MPa	X56, X60, L445, L450	-40°C	SDX S2Mo-EA2
		-50°C	SDX S3MoTiB
Rel ≥ 460 MPa	X65, X70, X80	-20°C	SDX S3Mo-EA4, SubCOR SL 735-1W-5W
		-40°C	SDX S3TiB
		-50°C	SDX S3MoTiB
		-60°F	SubCOR EM12K-S
TS > 70 ksi	A588, A516 Gr. 70	-60°F	SubCOR EM12K-S
		-80°F	SubCOR EM13K-S, SubCOR EM13K-S MOD

Approvals

With wire	CE
SDX S2Mo-EA2	✓

Flux/wire combinations for the Submerged Arc welding of non- and low-alloyed steels

Flux SWX 135 — Chemical composition all weld metal, typical values

With wire	%C	%Si	%Mn	%Mo	%Ti	%B
SDX S2	0.05	0.3	1.3			
SDX S2Si-EM12K	0.06	0.5	1.4			
SDX S2Mo-EA2	0.06	0.3	1.4	0.5		
SDX S3Mo-EA4	0.06	0.3	1.5	0.5		
SubCOR™ EM12K-S	0.06	0.3	1.2			
SubCOR EM13K-S	0.05	0.5	1.2			
SubCOR EM13K-S MOD	0.06	0.3	1.3			
Weld metal analyses of two-run pipe joint (high dilution)						
SDX S3TiB	0.06	0.5	1.6		0.024	0.0024
SDX S3MoTiB	0.06	0.5	1.4	0.3	0.022	0.0024
SubCOR SL 735-1W-5W	Depends on the type of solid wire used.					

Materials to be welded

Steel group	Typical examples of steel types	Impact requirement ≥47 J (≥20 ft-lbf)	Flux SWX 135 with wire
Normal-strength steel			
Rel ≤ 355 MPa	X42, X46, L235, L265, L295, L320	-40°C	SDX S2, SDX S2Si-EM12K
Rel ≥ 355 MPa	X52, L355, L360, L385L, 390, L415	-40°C	SDX S2, SDX S2Si-EM12K
TS > 58 ksi	A36, A709 Gr. 36,	-40°F	SubCOR™ EM12K-S
		-80°F	SubCOR EM13K-S, SubCOR EM13K-S MOD
TS > 65 ksi	A572 Gr. 50, A709 Gr. 50, A709 Gr. 50S, A992	-40°F	SubCOR EM12K-S
		-80°F	SubCOR EM13K-S, SubCOR EM13K-S MOD
High-strength steel			
Rel ≥ 420 MPa	X56, X60, L445, L450	-20°C	SDX S2Mo-EA2
		-40°C	SDX S3TiB
		-50°C	SDX S3MoTiB
Rel ≥ 460 MPa	X65, X70, X80	-20°C	S2Mo-EA2
		-40°C	SDX S3TiB, SubCOR SL 735-1W-5W
		-50°C	SDX S3MoTiB
TS > 70ksi	A588, A516 Gr. 70	-40°F	SubCOR EM12K-S
		-80°F	SubCOR EM13K-S, SubCOR EM13K-S MOD

Approvals

With wire	CE
SDX S2	✓
SDX S2Si-EM12K	✓
SDX S2Mo-EA2	✓

SWX 140

EN ISO 14174: S A FB 1 57 AC H5

Flux/wire combinations for the Submerged Arc welding of non- and low-alloyed steels

Description

SWX 140 is a fluoride-basic flux that combines high welding productivity with good low-temperature impact toughness at -50°C (-60°F) using standard SDX solid wires or at -60°C (-75°F) using specially developed SubCOR™ wires. It is a multi-purpose flux, suited for multi-layer welds in medium-thick and thick materials, but also for efficient two-run welding with multiple wire heads at high travel speed. It performs equally well in single-, twin- and tandem-wire welding and features good slag release, even in welds with a high interpass temperature. These characteristics make SWX 140 a versatile “production” flux for a wide range of applications in offshore fabrication, more demanding shipbuilding and pressure vessel fabrication. It is also an excellent flux for double jointing, both onshore and offshore onboard of pipe laying barges.

An extra safety margin on low-temperature impact values can be obtained from SubCOR cored wires. SubCOR SL 840 B HC is intended for single-wire welding, whereas the micro-alloyed SubCOR SL 735 B-1W-5W series represents a range of wires developed for multi-wire welding with up to five wires. SWX 140 is also successfully used in hardfacing for the repair of worn rails and rollers, providing consistent weld hardness. A special application is the joining of CRA-clad pipes for aggressive fluids, where the weld in the host pipe needs to retain its toughness after a heat treatment at 1000°C (1830°F) and 590°C (1095°F).

The flux is delivered in Hobart humidity-proof packaging — EAE bag or DoubleBag™ — eliminating the need to re-dry the flux.

- Offshore construction
- Demanding shipbuilding
- Double jointing
- Pressure vessels

Flux characteristics

Flux type	Fluoride-basic
Basicity index	2.0 (Boniszewski)
Alloy transfer	Slightly Mn alloying
Density	~1.2 kg/liter
Grain size	0.2–2.0 mm /10–70 mesh
HDM	< 5 ml/100 g weld metal
Current	DC+/AC
Re-drying unopened bag	Not required
Re-drying opened bag	See storage and handling recommendations

Flux main components

Al ₂ O ₃ + MnO	CaO + MgO	SiO ₂ + TiO ₂	CaF ₂
~30%	~25%	~20%	~20%

Metallurgical behavior

The diagrams show the typical weld metal analysis in relation to wire analysis for silicon and manganese. Single wire, ø 4.0 mm (5/32"), DC+, 30 V, 60 cm/min (24"/min)

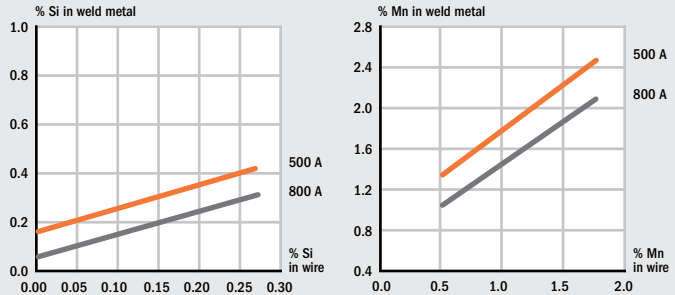

Flux SWX 140 — Classifications

Mechanical properties*

With wire	EN ISO	AWS	Temperature								YS ksi	TS ksi	E %	CVN ft-lbf	
			Re/Rp0.2 MPa	Rm MPa	A %	CVN J	-20°C	-40°C	-50°C	-60°C					0°F
SDX EM13K	AW	A5.17: F7A4-EM13K									77	87	29		40
SDX S2	AW	14171-A: S 38 5 FB S2	420	500	26	120	95	70	45						
SDX S2Si-EM12K	AW	14171-A: S 38 5 FB S2Si	A5.17: F7A6-EM12K	430	510	26	130	100	75	45	66	78	27		76 68
SDX S2Mo-EA2	AW	14171-A: S 46 4 FB S2Mo	A5.23: F7A6-EA2-A4	500	590	24	90	60			73	83	25		69
	SR ¹		A5.23: F7P6-EA2-A4	490	575	24	90	60	45		68	91	29		44 30
SubCOR™ EM12K-S	AW	A5.17: F7A6-EC1									60	70	32		110
SubCOR EM13K-S	AW	A5.17: F7A8-EC1									58	71	29		105
	SR ¹		A5.17: F6P8-EC1								51	66	34		143 142
SubCOR EM13K-S MOD	AW	A5.17: F7A10-EC1									72	82	29		161 105
	SR ¹		A5.17: F7P8-EC1								67	80	29	221	134
SubCOR 92-S	AW	A5.23: F8A10-ECM1-M1									79	93	26		85 52
	SR ²		A5.23: F8P8-ECM1-M1								71	84	27		103 77
SubCOR SL 735-1W-5W	AW	14171-A: S 46 4 FB T3	500	580	29	150	120								
SubCOR SL 840 HC	AW	14171-A: S 46 6 FB T3Ni1	520	570	30	140	120		100						
	SR ¹		520	570	30		140		120						
SubCOR SL 741	AW	26304: S 55 6 FB T3 Ni1Mo	560	650	18	100	80	70	60						
	SR ¹		510	560	20	100	80	70	60						
SubCOR 100F3-S	AW	A5.23: F10A10-ECF3-F3									101	109	24		57 44
	SR ¹		A5.23: F10P8-ECF3-F3								98	108	25		59 35

AW: as welded, all weld metal. SR: stress relieved, all weld metal. SR¹: 1150°F (620°C) / 1 h. SR²: 1125°F (605°C) / 1 h.
*Metric values are typical of EN ISO testing and imperial values are typical of AWS testing.

SWX 140 (continued)

EN ISO 14174: S A FB 1 57 AC H5

Flux/wire combinations for the Submerged Arc welding of non- and low-alloyed steels

Flux SWX 140 — Chemical composition all weld metal, typical values

With wire	%C	%Si	%Mn	%Ni	%Mo
SDX EM13K	0.05	0.2	1.2		
SDX S2	0.07	0.2	1.4		
SDX S2Si-EM12K	0.07	0.3	1.4		
SDX S2Mo-EA2	0.07	0.2	1.4		0.5
SubCOR™ EM12K-S	0.05	0.2	1.2		
SubCOR EM13K-S	0.05	0.2	1.2		
SubCOR EM13K-S MOD	0.08	0.3	1.2		
SubCOR 92-S	0.08	0.2	1.3	1.6	0.2
SubCOR SL 735-1W-5W	0.05	0.3	1.4		
SubCOR SL 840 HC	0.10	0.3	1.4	0.9	
SubCOR SL 741	0.06	0.3	1.2	0.9	0.5
SubCOR 100F3-S	0.09	0.3	1.5	0.8	0.5

Materials to be welded

Steel group	Typical examples of steel types	Impact requirement ≥47 J (≥20 ft-lbf)	Flux SWX 140 with wire
Normal-strength steel			
Rel ≤ 355 MPa	S235JR, A106 Gr. B, A333 Gr. 6, P235GH, S275JO, S275JR, P295GH	-40°C -50°C	SDX S2Mo-EA2 SDX S2, SDX S2Si-EM12K
Rel ≥ 355 MPa	S355J2, S355N, P355NL1, X52, L360, S355MCD, S355ML, P355GH	-40°C -50°C	SDX S2Mo-EA2 SDX S2, SDX S2Si-EM12K
TS > 58 ksi	A36, A709 Gr. 36,	-60°F -100°F	SubCOR™ EM12K-S SubCOR EM13K-S MOD
TS > 65ksi	A572 Gr. 50, A709 Gr. 50, A709 Gr. 50S, A992	-60°F -100°F	SubCOR EM12K-S SubCOR EM13K-S MOD
High-strength steel			
Rel ≥ 420 MPa	S420N, S460ML, P420ML2, S420MCD, S420G2+M, X60, L450	-40°C	SDX S2Mo-EA2, SDX S3Si-EH12
Rel ≥ 460 MPa	S460M, S460ML, S460ML2, S460MCD, S460G2+M X65, L450	-40°C -60°C	SDX S2 Mo-EA2, SDX S3Si-EH12, SubCOR SL 735-1W-5W SubCOR SL 840 HC
Rel ≥ 500 MPa	S500Q, S500QL, S500QL1, P500QL1, P500QL2, S500G2+M, S55Q, S550QL, S500QL1, X70, X75, X80	-50°C -60°C	SubCOR 741 SubCOR SL 840 HC
TS > 70ksi	A588, A516 Gr. 70	-60°F -100°F	SubCOR EM12K-S SubCOR EM13K-S MOD
TS > 75ksi	A572 Gr. 60, A913 Gr. 60, A871 Gr. 60	-100°F	SubCOR 92-S
TS > 80ksi	A572 Gr. 65, A871 Gr. 65, A537 Class 2	-100°F	SubCOR 92S
TS > 85ksi	A710 Gr. A Class 3 ≤ 2"	-100°F	SubCOR 100F3-S
TS > 90ksi	A710 Gr. A Class 1 ≤ 3/4"	-100°F	SubCOR 100F3-S
TS > 100ksi	A514 >2 1/2"	-100°F	SubCOR 100F3-S
Creep-resistant steel			
0.5% Mo	P295GH, P355GH, 16Mo3, 17Mo3, 14Mo6	-40°C	SDX S2Mo-EA1

Approvals

With wire	ABS	DNV	GL	LR	CE
SDX S2			4YTM		✓
SDX S2Si-EM12K					✓
SDX S2Mo-EA2	4Y 400 T	IV Y 40 T			✓
SubCOR™ SL 735 1W		III YTM	4YTM	3YM, 3YT	✓
SubCOR SL 735 2W+SDX S2		III YTM	4YTM	3YM, 3YT	✓
SubCOR SL 840 HC		3YM	6YM		✓

SWX 150

EN ISO 14174: S A FB 1 55 AC H5

Flux/wire combinations for the Submerged Arc welding of non- and low-alloyed steels

Description

Hobart SWX 150 is a high basicity, fluoride-basic agglomerated flux for low-temperature, high-strength and creep-resistant applications, including CTOD requirements. Its neutral character promotes a homogeneous weld chemistry and consistent mechanical properties throughout thick multi-layer welds. It produces low oxygen weld metal (~300 ppm), resulting in excellent impact toughness down to -60°C (-76°F) and below SWX 150 has a very good slag detachability, also in narrow gaps, along with smooth bead finish and tie-in. SWX 150 can be used in single- and multiple-wire operation and performs equally well on AC and DC+.

It is used for normal construction steel, high-strength steel, low-temperature steel and creep-resistant steel in demanding sectors such as offshore fabrication, pressure vessels and nuclear components. Use of the flux in combination with Hobart cored wires offers further opportunities to improve weld metal quality and productivity, making use of unique cored wire properties. Typical CTOD test results with SDX S3Si-EH12K solid wire, tested at -20°C (-4°F): 1.01, 1.01, 1.09 mm.

The flux is delivered in Hobart humidity-proof packaging — EAE bag or DoubleBag™ — eliminating the need to re-dry the flux.

- Offshore construction
- Offshore wind towers
- Structural pipes
- Civil construction
- Pressure vessels
- Nuclear applications
- Narrow gap welding
- Double-jointing
- High strength applications

Flux characteristics

Flux type	Fluoride-basic
Basicity index	3.3 (Boniszewski)
Alloy transfer	None
Density	~1.1 kg/liter
Grain size	0.2–2.0 mm /10–70 mesh
HDM	< 5 ml/100 g weld metal
Current	DC+/AC
Re-drying unopened bag	Not required
Re-drying opened bag	See storage and handling recommendations

Flux main components

Al ₂ O ₃ + MnO	CaO + MgO	SiO ₂ + TiO ₂	CaF ₂
~20%	~35%	~15%	~25%

Metallurgical behavior

The diagrams show the typical weld metal analysis in relation to wire analysis for silicon and manganese.

Single wire, ø 4.0 mm (5/32"), DC+, 30 V, 60 cm/min (24"/min)

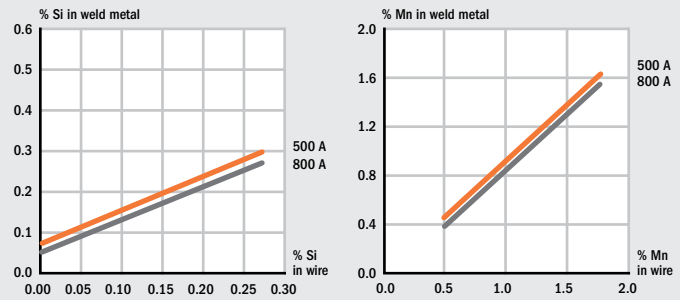

Flux SWX 150 — Classifications

Mechanical properties*

With wire	EN ISO	AWS	Mechanical properties*							YS ksi	TS ksi	E %	CVN			
			Re/Rp0.2 MPa	Rm MPa	A %	CVN J	ft-lbf									
			0°C -20°C -30°C -40°C -50°C -60°C -70°C							0°F -20°F -40°F -60°F -80°F -100°F						
SDX EM13K	AW	A5.17: F7A4-EM13K							68	74	27		42	28		
SDX S2Si-EM12K	AW 14171-A: S 38 5 FB S2Si	A5.17: F7A6-EM12K	420	500	22	130	85	65	35	68	77	31		90	27	
SDX S3Si-EH12K	AW 14171-A: S 46 6 FB S3Si	A5.17: F7A8-EH12K	490	550	29	140	115	80	60	74	83	31		142	122	
	SR [†]	A5.17: F7P8-EH12K	410	500	29	140	115	80	60	65	80	31		219	129	
SDX S4-EH14	AW 14171-A: S 50 4 FB S4		540	630	22	65	55	40								
	SR [†]		450	550	22	60	55	40								
SDX S2Mo-EA2	AW 14171-A: S 46 4 FB S2Mo	A5.23: F7A6-EA2-A2	485	570	23	75	55	40		76	84	27		106	44	
	SR [†]	A5.23: F7P6-EA2-A2	460	510	24	70	50	35		72	82	30		109	60	
SubCOR™ EM12K-S	AW	A5.17: F7A4-EC1								60	71	32	97			
SubCOR EM13K-S	AW	A5.17: F7A8-EC1								64	73	30			160	
	SR [†]	A5.17: F6P8-EC1								52	67	35			154	
SubCOR EM13K-S MOD	AW	A5.17: F7A8-EC1								70	79	29			103	
	SR [†]	A5.17: F7P8-EC1								65	78	32			36	
SubCOR SL 731	AW 14171: S 46 6 FB T3	A5.17: F8A6-EC1	500	600	27	160	130	100		71	86	27	120	95	70	
	SR [†]		470	570	28	130	110	80								
SDX S3Ni1Mo0.2-ENi5	AW 14171-A: S 46 6 FB S3Ni1Mo0.2	A5.23: F8A8-ENi5-Ni5	510	590	29		125	75		82	90	27			146	
	SR [†]	A5.23: F8P6-ENi5-Ni5	500	590	28			70		77	89	28			134	100
SDX S3Ni1Mo-EF3	AW 14171-A: S 62 6 FB S3Ni1Mo	A5.23: F10A8-EF3-F3	640	730	22	110	75	60	50	98	107	24			99	72
SDX S3Ni2.5CrMo	AW 26304: S 69 6 FB S3Ni2.5CrMo		710	800	18	95	75	65	55							
SubCOR 92-S	AW	A5.23: F8A10-ECM1-M1								78	88	26			91	78
	SR [†]	A5.23: F8P8-ECM1-M1								76	88	27			123	106

Table continues on next page >>

SWX 150 (continued)

EN ISO 14174: S A FB 1 55 AC H5

Flux/wire combinations for the Submerged Arc welding of non- and low-alloyed steels

Flux SWX 150 — Classifications			Mechanical properties*																	
With wire	EN ISO	AWS	Re/Rp0.2 MPa	Rm MPa	A %	CVN J	0°C -20°C -30°C -40°C -50°C -60°C -70°C					YS ksi	TS ksi	E %	CVN ft-lbf	0°F -20°F -40°F -60°F -80°F -100°F				
SubCOR™ F2-S	AW	A5.23: F10A10-ECF2-F2										95	104	23				86	58	
	SR ¹	A5.23: F10P10-ECF2-F2										91	101	25				39	28	
SubCOR 100F3-S	AW	A5.23: F10A10-ECF3-F3										101	109	24				57	44	
	SR ¹	A5.23: F10P10-ECF3-F3										98	108	25				59	35	
SubCOR 120-S	AW	A5.23: F11A10-ECM4-M4										111	118	23				77	52	
SubCOR SL 741	AW	26304: S 55 6 FB T3 Ni1Mo	550	640	19				100	80										
SubCOR SL 742	AW	26304: S 69 6 FB T3 Ni2.5CrMo	A5.23: F11A8-ECF5-F5	720	820	20	130		115	85							74	61		
	SR ²	26304: S 69 6 FB T3 Ni2.5CrMo		700	790	20	135		115	70										
SubCOR SL 745	AW	16304: S 89 4 FB T3Ni2.5Cr1Mo	920	1060	15				47											
SDX S2Ni1-ENi1	AW	14171-A: S 42 4 FB S2Ni1	A5.23: F7A8-ENi1-Ni1	440	530	25	130		65	45		70	80	29				135	108	
	SR ¹		A5.23: F7P8-ENi1-Ni1	430	530	25	130		90	60	45	65	77	30				177	135	
SDX S2Ni2-ENi2	AW	14171-A: S 46 7 FB S2Ni2	A5.23: F8A10-ENi2-Ni2	480	570	27	145		115	95	75	60	74	85	27			143	127	
	SR ¹		A5.23: F8P10-ENi2-Ni2	480	580	27	145		115	90	60	40	70	83	28			149	138	
SubCOR N1-S	AW		A5.23: F7A8-ECNi1-Ni1									61	73	26				104		
	SR ¹		A5.23: F7P10-ECNi1-Ni1									58	71	33				127	191	
SubCOR W-S	AW		A5.23: F7A6-ECW-W									71	80	28			129	66		
SDX CrMo1-EB2R	SR ⁴	24598: S S CrMo1 FB	A5.23: F8P2-EB2R-B2	490	620	22	100	80				80	91	25			129	88		
SDX CrMo2-EB3R	SR ⁴	24598: S S CrMo2 FB	A5.23: F8P0-EB3R-B3	530	630	22	110	80				82	97	24	92	20				
SubCOR B2-S	SR ⁴		A5.23: F9P2-ECB2-B2									93	96	23			92	18		
SubCOR B3-S	SR ⁴		A5.23: F9P2-ECB3-B3									103	117	18			25			
SubCOR SL P1	SR ⁴	24598: ST Mo FB		480	560	22	220	200	180											
SubCOR SL P1 MOD	SR ⁴	24598: ST MoV FB		420	530	22	70	40												
SubCOR SL P11	SR ⁴	24598: ST CrMo1 FB		510	600	26		200	150											
SubCOR SL P12 MOD	SR ⁴	24598: ~ ST CrMoV1 FB		540	630	17	60**													
SubCOR SL P22	SR ⁴	24598: ST CrMo2 FB		560	640	20	180													
SubCOR SL P24	SR ⁴	24598: ST Z FB		650	720	18	120	60												
SubCOR SL P36	SR ¹	24598: ST Z FB		580	640	23			110	80										
SubCOR SL P5	SR ⁵	24598: ST CrMo5 FB		470	590	25	200	150												

AW: as welded, all weld metal. SR: stress relieved, all weld metal. SR¹: 620°C (1150°F) / 1 h. SR²: 605°C (1125°F) / 1 h. SR³: 565°C (1050°F) / 1 h. SR⁴: 690°C (1275°F) / 1 h. SR⁵: 745°C (1375°F) / 1 h.
 *Metric values are typical of EN ISO testing and imperial values are typical of AWS testing. **Valid at +20°C (68°F).

Flux SWX 150 — Chemical composition all weld metal, typical values

With wire	%C	%Si	%Mn	%Cr	%Ni	%Mo	%V	%Cu
SDX EM13K	0.07	0.2	1.0					
SDX S2Si-EM12K	0.07	0.3	0.9					
SDX S3Si-EH12K	0.09	0.3	1.5					
SDX S4-EH14	0.09	0.15	1.9					
SDX S2Mo-EA2	0.07	0.2	0.9			0.5		
SDX S2Ni1-ENi1	0.07	0.2	0.9		0.9			
SDX S2Ni2-ENi2	0.08	0.2	1.0		2.1			
SDX S3Ni1Mo0.2-ENi5	0.09	0.25	1.4		0.9	0.2		
SDX S3Ni1Mo-EF3	0.09	0.2	1.5		0.9	0.5		
SDX S3Ni2.5CrMo	0.07	0.2	1.4	0.5	2.5	0.5		
SDX CrMo1-EB2R	0.07	0.3	0.9	1.1		0.5		
SDX CrMo2-EB3R	0.07	0.3	0.6	2.2		1.0		
SubCOR™ EM12K-S	0.05	0.2	0.9					
SubCOR EM13K-S	0.07	0.2	1.0					
SubCOR EM13K-S MOD	0.09	0.3	0.9					
SubCOR 92-S	0.05	0.2	1.0		1.6	0.2		
SubCOR F2-S	0.07	0.35	1.4		0.7	0.4		

Table continues on next page >>

Flux/wire combinations for the Submerged Arc welding of non- and low-alloyed steels

Flux SWX 150 — Chemical composition all weld metal, typical values

With wire	%C	%Si	%Mn	%Cr	%Ni	%Mo	%V	%Cu
SubCOR™ 100F3-S	0.09	0.3	1.5		0.8	0.5		
SubCOR 120-S	0.06	0.3	1.5	0.3	2.4	0.4		
SubCOR Ni1-S	0.05	0.2	1.0		1.6	0.2		
SubCOR W-S	0.03	0.4	0.6	0.5	0.5			0.4
SubCOR B2-S	0.07	0.4	0.4	1.2		0.5		
SubCOR B3-S	0.1	0.4	0.4	2.3		1.0		
SubCOR SL 731	0.08	0.6	1.6					
SubCOR SL 741	0.06	0.3	1.2		0.9	0.5		
SubCOR SL 742	0.08	0.4	1.6	0.5	2.2	0.5		
SubCOR SL 745	0.08	0.4	1.6	1.0	2.2	0.5		
SubCOR SL P1	0.07	0.4	1.0			0.5		
SubCOR SL P1 MOD	0.05	0.3	1.0	0.4	0.2	0.55	0.3	
SubCOR SL P11	0.07	0.4	1.0	1.1		0.5		
SubCOR SL P12 MOD	0.10	0.5	0.9	1.1	0.3	1.2	0.25	
SubCOR SL P22	0.09	0.3	1.1	2.3		1.1		
SubCOR SL P24	0.1	0.3	1.2	2.5		1.0	0.2	
SubCOR SL P36	0.05	0.3	1.3		0.9	0.5		
SubCOR SL P5	0.05	0.4	1.1	5.0		0.6		

Materials to be welded

Steel group	Typical examples of steel types	Impact requirement ≥47 J (≥20 ft-lbf)	Flux SWX 150 with wire
Normal-strength steel			
Rel ≤ 355 MPa	S235JR, A106 Gr. B, A333 Gr. 6, P235GH, S275J0, S275JR	-50°C	SDX S2Si-EM12K
		-60°C	SDX S3Si-EH12K
Rel ≥ 355 MPa	S355J2, S355N, P355NL1, X52, L360, S355MCD, S355ML	-50°C	SDX S2Si-EM12K
		-60°C	SDX S3Si-EH12K
TS > 58 ksi	A36, A709 Gr. 36,	-40°F	SubCOR™ EM12K-S
		-80°F	SubCOR EM13K-S
		-100°F	SubCOR EM13K-S MOD
TS > 65ksi	A572 Gr. 50, A709 Gr. 50, A709 Gr. 50S, A992	-40°F	SubCOR EM12K-S
		-80°F	SubCOR EM13K-S
		-100°F	SubCOR EM13K-S MOD
High-strength steel			
Rel ≥ 420 MPa	S420N, S460ML, P420ML2, S420MCD, S420G2+M, X60, L450	-40°C	SDX S2Mo-EA2, SDX S2Ni1-ENi1
		-60°C	SDX S3Si-EH12K
Rel ≥ 460 MPa	S460M, S460ML, S460ML2, S460MCD, S460G2+M, X65, L450	-40°C	SDX S2Mo-EA2, SubCOR SL 731
		-60°C	SDX S3Si-EH12K, SDX S2Ni1Mo0.2-ENi5
		-70°C	SDX S2Ni2-ENi2
Rel ≥ 500 MPa	S500QL, S500QL1, P500QL1, P500QL2, X70, S500G2+M, B1 4NVE 500, X70, X80	-40°C	SDX S4-EH12
		-60°C	SubCOR SL 741
Rel ≥ 620 MPa	S550QL, NVE550, S600Q1, S620Q, S620QL, NVE620	-40°C	SDX S3Ni1.5CrMo
		-60°C	SDX S3Ni1Mo-EF3
Rel ≥ 690 MPa	S690Q, S690QL, S690QL1, NVE690, X100	-60°C	SubCOR SL 742, SDX S3Ni2.5CrMo
Rel ≥ 890 MPa	S890QL1, S960QL1, A714, A709, A515, A517	-40°C	SubCOR SL 745

Table continues on next page >>

SWX 150 (continued)

EN ISO 14174: S A FB 1 55 AC H5

Flux/wire combinations for the Submerged Arc welding of non- and low-alloyed steels

Materials to be welded

Steel group	Typical examples of steel types	Impact requirement ≥47 J (≥20 ft-lbf)	Flux SWX 150 with wire
High strength steel			
TS > 70ksi	A588, A516 Gr.70	-60°F	SubCOR™ EM12K-S
		-80°F	SubCOR EM13K-S MOD
	A709 Gr. HPS50W, A537 Class 1	-100°F	SubCOR N1-S
TS > 75ksi	A572 Gr. 60, A913 Gr. 60, A871 Gr. 60	-100°F	SubCOR 92-S
TS > 80ksi	A572 Gr. 65, A871 Gr. 65, A537 Class 2	-100°F	SubCOR 92S, SubCOR F2-S
TS > 85ksi	A710 Gr. A Class 3 ≤ 2"	-100°F	SubCOR 100F3-S
TS > 90ksi	A710 Gr. A Class 1 ≤ 3/4"	-100°F	SubCOR 100F3-S
TS > 100ksi	A514 >2 1/2"	-100°F	SubCOR 100F3-S
TS > 110ksi	A517, A514 <2 1/2"	-100°F	SubCOR 120-S
Weathering			
TS > 70ksi	A588	-60°F	SubCOR W-S
Chromium Molybdenum			
TS > 75ksi, 1% Cr, 0.5%Mo	A387 Gr. 11	-20°F	SubCOR B2-S
TS > 75ksi, 2% Cr, 1%Mo	A387 Gr. 22	-20°F	SubCOR B3-S
Creep-resistant steel			
EN	ASTM		
P235GH-P355GH, 16Mo3, P235T1/T2-P460NL2, L210-L445MB, S255-S460QL1	A355 P1, A285 Gr. C, A515 Gr. 70, A516 Gr. 70		SubCOR SL P1
14MoV6-3 (1.7715)	A405		SubCOR SL P1 MOD
13CrMo4-5, G17CrMo5-5, G22CrMo5-4	A355 P11, A387 Gr. 11		SubCOR SL P11
21CrMoV5-11, GS17CrMoV5-17	A 387 Gr. 11		SubCOR SL P12 MOD
15NiCuMoNb5/WB 36, 20MnMoNi4-5, 11NiMoV53, 17MnMoV6-4	A355 P36		SubCOR SL P36
10CrMo9-10, 12CrMo9-10	A355 P22, A387 Gr. 22		SubCOR SL P22
10CrMo9-10, 12CrMo9-10, 7CrMoVTiB10-10 (P24)	A355 P22		SubCOR SL P24
X12CrMo5	A355 P5, A387 Gr. 5		SubCOR SL P5
X12CrMo9-1, X7CrMo9-1	A355 P9, A387 Gr. 9		SubCOR SL P9
X12CrMo9-1, X10CrMoVNb9-1	A355 P91, A387 Gr. 91		SubCOR SL P91
X12CrMo9-1, X10CrMoVNb9-1, X10CrMoVNb9-2, X12CrWVNb12-2-2, X20CrMoWV12-1, X20CrMoV12-1	A355 P92		SubCOR SL P92

Approvals

With wire	ABS	BV	DNV	GL	LR	CWB	DB	TÜV	CE
SDX EM13K	4YM								
SDX S2	3YM	A3YM	III YM	3YM	BF 3YM NR			✓	✓
SDX S2Si-EM12K					BF 5Y46M H5	F49A6-EM12K			✓
SDX S2Mo-EA2						F55A5-EA2-A2		✓	✓
SDX S3-EH10K								✓	
SDX S3Si-EH12K	5YQ460	A 5Y46M H5	V Y46(H5)	6Y46MH5	BF 5Y46M H5	F49A6-EH12K		✓	✓
SDX S2Ni2-ENi2									✓
SDX S3Ni1Mo-EF3	4YQ550M		IVY55M						✓
SDX S3NiMo0.2-ENi5	4YQ460M		IVY46M						✓
SDX S3Ni2.5CrMo									✓
SubCOR™ EM13K-S	4YM								
SubCOR EM13K-S MOD	4YM								
SubCOR 120-S	F11A10-ECM4-M4								
SubCOR SL 731	3YM H5	3YM	III YM	3YM	5Y46 H5		✓	✓	✓
SubCOR SL 735 1W			IIIYTM	3YTM	3YM, 3YT				✓
SubCOR SL 735 2W+SDX S2	3YTM		IIIYTM	3YTM	3YM, 3YT				✓
SubCOR SL 741									✓
SubCOR SL 742	5YQ690M H5	A 5Y69M H5	V Y69MS H5	6Y69 H5	BF 5Y69M H5			✓	✓

Note: SubCOR SL P1, P1 MOD, P11, P12, P22, P24, P36, and P5 are all CE approved.

SWX 160

EN ISO 14174: S A FB 1 55 AC H5

Flux/wire combinations for the Submerged Arc welding of non- and low-alloyed steels

Description

Hobart SWX 160 is a high basicity, fluoride-basic agglomerated flux specially developed for welding creep-resistant Cr-Mo steels, including step cooling applications. It is also the best choice for welding high-strength steels giving very good mechanical properties and excellent slag detachability. The slag detachability makes SWX 160 a perfect flux for narrow gap welding along with smooth bead finish and tie-ins.

SWX 160 produces a clean weld metal with very low levels of impurities, allowing for a low X-factor when welded with suitable wires. The weld metal has an oxygen content of about 300 ppm and a diffusible hydrogen level lower than 5 ml/100 g with a correctly set up welding process. SWX 160 can be used in single- and multi-wire operation and performs well both on AC and DC+.

The flux is delivered in Hobart humidity-proof EAE bag, eliminating the need to re-dry the flux.

- Pressure vessels
- Nuclear applications
- High strength applications
- Offshore construction

Flux characteristics

Flux type	Fluoride-basic
Basicity index	2.7 (Boniszewski)
Alloy transfer	None
Density	~1.1 kg/liter
Grain size	0.2–2.0 mm /10–70 mesh
HDM	< 5 ml/100 g weld metal
Current	DC+/AC
Re-drying unopened bag	Not required
Re-drying opened bag	See storage and handling recommendations

Flux main components

AL ₂ O ₃ + MnO	CaO + MgO	SiO ₂ + TiO ₂	CaF ₂
~20%	~35%	~15%	~25%

Metallurgical behavior

The diagrams show the typical weld metal analysis in relation to wire analysis for silicon and manganese.

Single wire, ø 4.0 mm (5/32"), DC+, 30 V, 60 cm/min (24"/min)

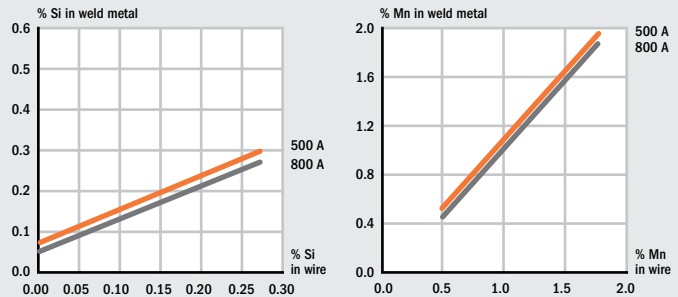

Flux SWX 160 — Classifications

Mechanical properties*

With wire	EN ISO	AWS	Mechanical properties*						YS ksi	TS ksi	E %	CVN ft-lbf				
			Re/Rp0.2 MPa	Rm MPa	A %	CVN J	+20°C	0°C				-20°C	-30°C	-40°C	-60°C	0°F
SDX S3Si-EH12K	SR ¹ 14171-A: S 38 6 FB S3Si	A5.17: F7P8-EH12K	410	500	28				60	75	28				80	50
SDX CrMo1-EB2R	SR ² 24598-A: S S CrMo1 FB	A5.23: F8P2-EB2R-B2R	480	590	22			110	90	70	85	22	80	65		
		SR ³	480	580	22			110	90	70	85	22	80	65		
SDX CrMo2-EB3R**	SR ² 24598-A: S S CrMo2 FB	A5.23: F8P2-EB3R-B3R	530	630	22			100	90	80	90	22	75	65		
		SR ³	500	590	22			100	90	75	85	22	75	65		
SDX S3Ni2.5CrMo	AW 26304-A: S 79 6 FB S3Ni2.5CrMo		820	880	18			90	60	120	130	18		65	45	
SubCOR™ SL P91	SR ⁴ 24598-A: ST CrMo1 FB		560	670	20	80	50									
SubCOR 120-S	AW	A5.23: F11A6-ECM4-M4	770	830	19			80		110	120	19		60		
SubCOR SL 742	AW 26304-A: S 69 6 FB T3 Ni2.5CrMo	A5.23: F11A8-ECF5-F5	730	830	17			120	90	105	120	17		90	65	

AW: As welded, all weld metal. SR: stress relieved, all weld metal. SR¹: PWHT 1150°F (620°C) / 1 h. SR²: PWHT 1275°F (690°C) / 1 h. SR³: 1230°F (665°C) / 20 h. SR⁴: PWHT 1400°F (760°C) / 3 h.

*Metric values are typical of EN ISO testing and imperial values are typical of AWS testing. **Step cooling data available.

Flux/wire combinations for the Submerged Arc welding of non- and low-alloyed steels

Flux SWX 160 — Chemical composition all weld metal, typical values

With wire	%C	%Si	%Mn	%P	%S	%Cr	%Ni	%Mo	%V	X ppm
SDX S3Si-EH12K	0.09	0.4	1.5	0.004	0.002					
SDX CrMo1-EB2R	0.09	0.3	0.9	0.006	0.003	1.2		0.4		7
SDX CrMo2-EB3R	0.09	0.3	0.7	0.007	0.003	2.3		1.0		8
SDX S3Ni2.5CrMo	0.08	0.4	1.5	0.010	0.003	0.5	2.3	0.5		
SubCOR™ SL P91	0.10	0.4	1.0	0.018	0.011	8.4	0.3	0.9	0.1	
SubCOR 120-S	0.07	0.4	1.6	0.009	0.005	0.3	2.4	0.5		
SubCOR SL 742	0.08	0.4	1.7	0.012	0.007	0.4	2.0	0.4		

Description

Hobart SWX 220 an agglomerated neutral-basic flux for the single- or multi-run welding of stainless steel in all plate thicknesses. It can be combined with a wide range of SDX submerged arc wires for the welding of all standard austenitic stainless steel grades, for duplex and super duplex stainless steel, for dissimilar joints and for higher-alloyed stainless steel grades. Multi-run welding is favored for excellent slag detachability and smooth side-wall blending, while the overall weld appearance is very nice. It yields welds with good mechanical properties, including excellent low-temperature impact toughness.

A wide range of applications are found in transport and processing installations in the offshore oil and gas and petrochemical industries, in tanks and appliances of chemical tankers, in paper and pulp processing plants and in nuclear power stations.

The flux is delivered in Hobart humidity-proof EAE bag, eliminating the need to re-dry the flux.

- Offshore fabrication
- Petrochemical industry
- Chemical tankers
- Duplex grades
- Nuclear applications
- Paper and pulp plants
- Equipment for the food industry

Flux characteristics

Flux type	Aluminate-fluoride
Basicity index	1.9 (Boniszewski)
Alloy transfer	None
Density	~1.2 kg/liter
Grain size	0.2–2.0 mm /10–70 mesh
Current	DC+
Re-drying unopened bag	Not required
Re-drying opened bag	See storage and handling recommendations

Flux main components

AL ₂ O ₃ + MnO	CaO + MgO	SiO ₂ + TiO ₂	CaF ₂
~30%	~25%	~20%	~20%

Flux SWX 220 — Classifications

With wire	EN ISO	AWS	Mechanical properties*							YS ksi	TS ksi	E %	CVN ft-lbf	
			Re/Rp0.2 MPa	Rm MPa	A %	CVN J	-20°C -40°C -60°C -196°C							-4°F -40°F -76°F -321°F
SDX 308L	14343-A: S 19 9 L	A5.9: ER308L	390	550	36	100	60	50	57	80	36	74	44	37
SDX 309L	14343-A: S 23 12 L	A5.9: ER309L	420	580	33	90	65	35	61	84	90	66	48	26
SDX 309LMo	14343-A: S 23 12 2 L		420	620	33	90			61	90	90	66		
SDX 316L	14343-A: S 19 12 3 L	A5.9: ER316L	390	560	36	100	90	40	57	81	36	74	66	30
SDX 317L	14343-A: S 19 13 4 L	A5.9: ER317L	430	600	30	90	50	40	62	87	30	66	37	30
SDX 347	14343-A: S 19 9 Nb	A5.9: ER347	440	620	36	100	80	20	64	90	36	74	59	15
SDX 2209	14343-A: S 22 9 3 N L	A5.9: ER2209	620	780	26	130	100	80	90	113	26	96	74	41
SDX 2594	14343-A: S 25 9 4 N L	A5.9: ER2594	630	830	28	80	60		91	120	28	59	44	

*Metric values are typical of EN ISO testing and imperial values are typical of AWS testing.

Flux SWX 220 — Chemical composition all weld metal, typical values

With wire	%C	%Si	%Mn	%Cr	%Ni	%Mo	%Nb	%N	FN
SDX 308L	0.02	0.6	1.4	19.5	10.0				7
SDX 309L	0.02	0.6	1.4	23.0	14.2	2.8			10
SDX 309LMo	0.02	0.6	1.4	21.5	14.2	2.8			12
SDX 316L	0.02	0.6	1.4	18.3	11.3	2.8			8
SDX 317L	0.02	0.6	1.4	19.5	14.3	3.5			6
SDX 347	0.04	0.6	1.0	19.1	9.3		0.5		8
SDX 2209	0.02	0.7	1.2	22.5	9.0	3.2		0.13	48
SDX 2594	0.01	0.45	0.6	22.5	9.2	4.0		0.26	42

Flux/wire combinations for the Submerged Arc welding of stainless steel

Materials to be welded

AISI	EN 10088-1/2	Material nr.	UNS	Flux SWX 220 with wire
304	X4 CrNi 18 10	1.4301	S30409	SDX 308L
304L	X2 CrNi 19 11	1.4306	S30403	SDX 308L
304LN	X2 CrNiN 18 10	1.4311	S30453	SDX 308L
316	X4 CrNiMo 17 12 2	1.4401	S31600	SDX 316L
316	X4 CrNiMo 17 13 3	1.4436		SDX 316L
316L	X2 CrNiMo 17 12 2	1.4404	S31603	SDX 316L
316L	X2 CrNiMo 18 14 3	1.4435	S31603	SDX 316L
317L	X2 CrNiMoN 17 13 5	1.4439	S31726	SDX 317L
321	X6 CrNiTi 18 10	1.4541	S32100	SDX 347, SDX 308L for service temperatures below 400°C
347	X6 CrNiNb 18 10	1.4550	S34700	SDX 347, SDX 308L for service temperatures below 400°C
	X2 CrNiMoN 22 5 3	1.4462		SDX 2209
		1.4507		SDX 2594
	Dissimilar welds, moderate dilution			SDX 309L
	Dissimilar welds, high dilution, hot crack resistant			SDX 309L Mo

Approvals

With wire	CE
SDX 2209	✓

SWX 282

EN ISO 14174: S A AF 2 DC

Flux/wire combinations for the Submerged Arc welding of Ni-base alloys

Description

Hobart SWX 282 is an agglomerated neutral-basic flux for the single- or multi-run welding of Ni-base alloys, such as Alloy 82, Alloy 600 and Alloy 625. This aluminate-fluoride flux features excellent slag detachability and very good CVN impact properties at temperatures down to -196°C (-321°F).

The flux is delivered in Hobart humidity-proof EAE bag, eliminating the need to re-dry the flux.

- Offshore oil and gas processing
- Pulp and paper industry

Flux characteristics

Flux type	Aluminate-fluoride
Basicity index	1.9 (Boniszewski)
Alloy transfer	None
Density	~1.2 kg/liter
Grain size	0.2–2.0 mm /10–70 mesh
Current	DC+
Re-drying unopened bag	Not required
Re-drying opened bag	See storage and handling recommendations

Flux main components

AL ₂ O ₃ + MnO	CaO + MgO	SiO ₂ + TiO ₂	CaF ₂
~30%	~25%	~20%	~20%

Flux SWX 282 — Classifications

With wire	EN ISO	AWS	Mechanical properties *				YS ksi	TS ksi	E %	CVN ft-lbf
			Re/Rp0.2 MPa	Rm MPa	A %	CVN J				
			-196°C				-321°F			
SDX NiCr-3	18274: S Ni6082	A5.14: ERNiCr-3	420	570	34	70	61	83	34	52
SDX NiCrMo-3	18274: S Ni6625	A5.14: ERNiCrMo-3	470	700	40	60	68	102	40	44

*Metric values are typical of EN ISO testing and imperial values are typical of AWS testing.

Flux SWX 282 - Chemical composition all weld metal, typical values

With wire	%C	%Si	%Mn	%Cr	%Ni	%Mo	%Nb	%Fe
SDX NiCr-3	0.01	0.3	0.3	19	Bal.	0.5	2.5	<3
SDX NiCrMo-3	0.01	0.3	0.3	21	Bal.	9	3	<3

Materials to be welded

	Flux SWX 282 with wire:
Alloy 82	SDX NiCr-3
Alloy 600	SDX NiCr-3
Alloy 625	SDX NiCrMo-3

SWX 305

EN ISO 14174: S A AAS 2B DC

Flux/strip combinations for the Submerged Arc strip cladding of stainless strips

Description

Acid aluminium-silicate, agglomerated flux designed for Submerged Arc strip cladding with stainless strips on mild- or low-alloyed steel. It has good welding characteristics and gives a smooth bead appearance and easy slag removal. SWX 305 is a non-alloying flux.

The flux is delivered in Hobart humidity-proof EAE bag, eliminating the need to re-dry the flux.

- Offshore fabrication
- Pressure vessels
- Petrochemical industry
- Paper and pulp plants
- Offshore oil and gas processing

Flux characteristics

Flux type	Acid-aluminium-silicate
Basicity index	1.1 (Boniszewski)
Alloy transfer	None
Density	~1.1 kg/liter
Grain size	0.2–2.0 mm /10–70 mesh
Current	DC+
Re-drying unopened bag	Not required
Re-drying opened bag	See storage and handling recommendations

Flux main components

Al ₂ O ₃ + MnO	CaO + MgO	SiO ₂ + TiO ₂	CaF ₂
~20%	~5%	~10%	~60%

Flux SWX 305 — Chemical composition all weld metal, typical values

With strip	%C	%Si	%Mn	%Cr	%Ni	%Mo	%Nb	%N	FN
Cromastrip 308L	0.02	0.6	1.0	19.0	10.5	0.1		0.03	~6
Cromastrip 316L	0.02	0.7	1.1	18.0	13.0	2.2		0.02	~7
Cromastrip 347	0.02	0.7	1.1	19.0	10.5	0.1	0.4	0.03	~8

All analyses in second layer, first layer welded with Cromastrip 309L.

SWX 330

EN ISO 14174: ES A FB 2B DC

Flux/strip combinations for Electroslag strip cladding

Description

Hobart SWX 330 is a fluoride-basic, non-alloying agglomerated flux designed for standard-speed Electroslag strip cladding with austenitic stainless strips of the AWS EQ300 series. It has a high current carrying capacity and can be used for single- or multi-layer cladding.

It features excellent slag removal, also on preheated surfaces, leaving a bright deposit with smooth overlap between runs.

The flux is delivered in Hobart humidity-proof EAE bag, eliminating the need to re-dry the flux.

- Pressure vessels
- Petrochemical industry
- Paper and pulp plants
- Offshore oil and gas processing
- Nuclear

Flux characteristics

Flux type	Fluoride-basic
Basicity index	3.8 (Boniszewski)
Alloy transfer	None
Density	1.1 kg/liter
Grain size	0.2–1.2 mm /16–70 mesh
Current	DC+
Re-drying unopened bag	Not required
Re-drying opened bag	See storage and handling recommendations

Flux main components

AL ₂ O ₃ + MnO	CaO + MgO	SiO ₂ + TiO ₂	CaF ₂
~25%	~0%	~10%	~65%

Flux SWX 330 — Chemical composition all weld metal, typical values

With strip	%C	%Si	%Mn	%Cr	%Ni	%Mo	%Nb	%N	FN*	Deposit type
Cromastrip 21.11 L	0.02	0.5	1.2	20.0	11.0	0.2		0.05	4	308L
Cromastrip 21.13.3 L	0.02	0.5	1.3	19.0	13.0	3.0		0.05	6	316L
Cromastrip 21.11 LNb	0.02	0.5	1.2	20.0	11.0	0.2	0.4	0.05	4	347

Single-layer composition. Parameters: 1350 A, 25 V, travel speed 22 cm/min. (9"/min.). Strip 60 x 0.5 mm.

*Ferrite number according to WRC-92.

SWX 340

EN ISO 14174: ES A FB 2B DC

Flux/strip combinations for Electroslag strip cladding

Description

Hobart SWX 340 is a fluoride-basic, non-alloying agglomerated flux designed for up to 45 centimeter per minute (17.7 IPM) high-speed Electroslag strip cladding with stainless strips. It has a very high current carrying capacity and features excellent slag removal and a bright deposit with smooth overlaps.

High-speed Electroslag welding is normally performed using strips from the SAW strip cladding range.

The flux is delivered in Hobart humidity-proof EAE bag, eliminating the need to re-dry the flux.

- Pressure vessels
- Petrochemical industry
- Cladding of pipes for oil and gas
- Offshore oil and gas processing

Flux characteristics

Flux type	Fluoride-basic
Basicity index	4.1 (Boniszewski)
Alloy transfer	None
Density	1.1 kg/liter
Grain size	0.2–1.2 mm /16–70 mesh
Current	DC+
Re-drying unopened bag	Not required
Re-drying opened bag	See storage and handling recommendations

Flux main components

AL ₂ O ₃ + MnO	CaO + MgO	SiO ₂ + TiO ₂	CaF ₂
~20%	~5%	~5%	~70%

Flux SWX 340 — Chemical composition all weld metal, typical values

Strip in 1st layer	Strip in 2nd layer	%C	%Si	%Mn	%Cr	%Ni	%Mo	%Nb	%N	FN*	Deposit type
Cromastrip 309LNb		0.025	0.4	1.4	19.5	10.5		0.4	0.025	9	347
Cromastrip 309L	Cromastrip 308L	0.020	0.5	1.2	19.5	10.5			0.035	8	308L
Cromastrip 309LMo	Cromastrip 316L	0.025	0.5	1.3	17.5	12.0	2.5		0.045	5	316L
Cromastrip 309LNb	Cromastrip 347	0.020	0.5	1.3	19.5	10.5		0.4	0.025	9	347

Single-layer composition. Parameters: 1450 A, 26 V, travel speed 31 cm/min. (12"/min.).

Dual-layer composition. 1st layer parameters: 1450 A, 26 V, travel speed 33 cm/min. (13"/min.). 2nd layer parameters: 1400 A, 26 V, travel speed 31 cm/min. (12"/min.).

*Ferrite number according to WRC-92.

SWX 382

EN ISO 14174: ES A AF 2B DC and S A AF 2 AC

Flux/strip combinations for Electroslag strip cladding

Description

Hobart SWX 382 is a high-basic, non-alloying, agglomerated flux primarily designed for standard-speed Electroslag strip cladding with Ni-based strips. It has a high current carrying capacity and can be used for single- or multi-layer cladding with strips. It features excellent slag removal, also on preheated surfaces, leaving a bright deposit with smooth overlap between runs.

The flux is also suitable for Submerged Arc overlay applications using Ni-base wires producing a smooth weld with excellent slag detachability.

The flux is delivered in Hobart humidity-proof EAE bag, eliminating the need to re-dry the flux.

- Pressure vessels
- Petrochemical industry
- Paper and pulp plants
- Oil and gas processing

Flux characteristics

Flux type	Aluminate-fluoride
Basicity index	3.7 (Boniszewski)
Alloy transfer	None
Density	1.1 kg/liter
Grain size	0.2–1.2 mm /16–70 mesh
Current	DC+
Re-drying unopened bag	Not required
Re-drying opened bag	See storage and handling recommendations

Flux main components

AL ₂ O ₃ + MnO	CaO + MgO	SiO ₂ + TiO ₂	CaF ₂
~20%	~5%	~10%	~60%

Flux SWX 382 — Chemical composition all weld metal, typical values

With strip	%C	%Si	%Mn	%Cr	%Ni	%Mo	%Nb	%Fe	Deposit type
Cromastrip NiCr-3*	0.03	0.6	2.7	18.0	Bal.		2.1	9	
Cromastrip NiCr-3**	0.02	0.5	3.0	19.5	Bal.		2.3	4	Alloy 82
Cromastrip NiCrMo-3*	0.03	0.4	0.3	20.0	Bal.	9	2.9	9	
Cromastrip NiCrMo-3**	0.02	0.3	0.2	21.5	Bal.	9	3.2	4	Alloy 625

*1st layer, 2 mm below surface. Welding parameters: 1200 A, 23 V, 18 cm/min (7"/min). Strip 60 x 0.5 mm.

**2nd layer, 2 mm below surface. Welding parameters: 1200 A, 23 V, 18 cm/min (7"/min). Strip 60 x 0.5 mm.

SWX HF-N

Flux/wire combinations for Submerged Arc hardfacing

Description

Hobart SWX HF-N is a neutral agglomerated fluoride-basic Submerged Arc flux for hard surfacing. It is designed for use with solid and tubular wires of the 400 series as well as low-alloy wires. It has very good recovery of alloying elements of the tubular wires, such as Cr, Ni, Mo, Nb and V.

Hobart SWX HF-N has excellent hot slag removal up to 450°C (850°F) and can be used when welding with twin-arc or oscillating techniques. The weld beads are smooth and uniform and the weld metal has good wetting action. The flux is delivered in Hobart humidity-proof packaging — EAE bag or DoubleBag™ — eliminating the need to re-dry the flux.

- Reconditioning of continuous cast rollers
- Reconditioning of crusher rollers for the mining and forest industry, sugar mills, etc.

Flux characteristics

Flux type	Fluoride-basic
Basicity index	2.6 (Boniszewski)
Alloy transfer	None
Density	1.2 kg/liter
Grain size	0.2–2.0 mm /10–70 mesh
Current	DC+
Re-drying unopened bag	Not required
Re-drying opened bag	See storage and handling recommendations

Flux main components

AL ₂ O ₃ + MnO	CaO + MgO	SiO ₂ + TiO ₂	CaF ₂
~19%	~34%	~18%	~29%

Flux SWX HF-N — Chemical composition all weld metal, typical values

With wire	%C	%Si	%Mn	%Cr	%Ni	%Mo	%Cu	%V	%Nb	%N	%W	%Co
Tube-Alloy® 242-S MOD	0.14	0.8	2.0	3.0		0.75						
Tube-Alloy 810-S	0.28	0.7	1.0	5.5		3.5						
Tube-Alloy 8620-S	0.06	0.8	1.4	0.5	0.4	0.2						
Tube-Alloy 865-S MOD	0.18	0.4	1.1	13.5	2.3	1.0	0.15		0.15			
Tube-Alloy 875-S	0.13	0.4	1.2	12.5	2.4	1.4		0.20		0.10		2.0
Tube-Alloy 952-S	0.27	0.6	1.2	12.8	0.6	1.8		0.19	0.18		1.4	
Tube-Alloy A250-S	0.19	0.5	1.0	12.3								
Tube-Alloy A2JL-S	0.04	0.6	0.8	13.5	2.0	1.0						
Tube-Alloy BU-S	0.12	0.8	1.8	0.7								

Hardness HRC* — Typical values

With wire	As deposited			Time (h)	After tempering		
	Layer 1	Layer 2	Layer 3		510°C (950°F)	565°C (1050°F)	620°C (1150°F)
Tube-Alloy® 242-S MOD	29	38	39				
Tube-Alloy 810-S	45	48	52	8	58	58	48
				18	52	52	48
Tube-Alloy 8620-S	12	19	21	6	19	16	15
				10	18	15	13
				20	17	12	7
Tube-Alloy 865-S MOD	45	46	48	6	47	43	35
				10	43	37	32
				20	42	36	31
Tube-Alloy 875-S	45	45	45				
Tube-Alloy 952-S	40	45	49	8	52	50	43
Tube-Alloy A250-S	44	46	48	6	33	28	24
				10	32	28	23
				20	32	23	22
Tube-Alloy A2JL-S	40	40	35	6	29	23	21
				10	25	22	19
				20	22	22	19
Tube-Alloy BU-S	20	26	30	6	24	21	20
				10	23	20	19
				20	22	19	17

*Hardness measured according to Rockwell C.

SWX 010

Powder backing for one-sided welding

Description

Hobart SWX 010 is an agglomerated backing powder for one-sided welding with the use of copper supports. It contains special components which enhance solidification of the slag to provide a regular and smooth root pass profile. It features excellent slag detachability.

SWX 010 powder backing is non-alloying and has no influence on weld metal properties. Typical applications are the one-sided welding of panel sections in shipbuilding and the joining of strips in spiral pipe mills. Suited for multi-wire operations. It is supplied in moisture-proof cans and must be used without re-drying.

- Shipbuilding
- Spiral pipe mills

Flux characteristics

Flux type	Not applicable
Basicity index	Not applicable
Alloy transfer	None
Density	1.1 kg/liter
Grain size	0.2–1.6 mm /12–70 mesh
Current	Not applicable
Re-drying unopened bag	Shall not be re-dried
Re-drying opened bag	See storage and handling recommendations

Powder main components

AL ₂ O ₃ + MnO	CaO + MgO	SiO ₂ + TiO ₂	CaF ₂
~15%	~50%	~30%	~0%

Storage, recycling and re-drying

Store the powder backing in the sealed can. Re-close lid after opening. Make sure the sealing is in the correct position. The powder backing should not be re-dried.

Health and safety

Do not breath the fumes. Use adequate fume extraction system and/or personal protection equipment. Study the Material Safety Data Sheet carefully.

Approval Certificates

Certificate of Approval

Zulassungsbescheinigung

WF 1350177 HH

Certificate no.
Beschäftigungs-Nr.:

The Welding Consumables
Die Schweißzusätze und -hilfsstoffe
Electrode/Wire Manufacturer/Supplier
Elektroden-/Draht-Hersteller/Lieferer

Wire-Flux-Combination
ITW Welding GmbH
(ehemals Drahtzug Stein wire & welding GmbH & Co. KG)
SDX S3Si-EH12K

Brand
Marke:
Flux/Shielding Gas Manufacturer/Supplier
Schweißgasgeber-/Schutzgas-Hersteller/Lieferer

Brand
Marke:

Classification
Klassifizierung (DIN, EN, ISO o.ä.)
are approved based upon the approval test as follows *:
werden aufgrund der Zulassungsprüfung wie folgt zugelassen*:

Grade, Suffix(es)
Grad/grad, Zusatzzeichen

Welding Process
Schweißprozess

Welding Position(s)
Schweißposition(en)

Diameter (mm)
Durchmesser (mm)

Welding Current/Polarity
Schweißstrom/Polartität

Range of Application:
Anwendungsbereich:
Materials and Heat Treatment:
Werkstoffe und Wärmebehandlung:

Service Temperature:
Anwendungstemperatur:

Remarks:
Bemerkungen:

Initial test: 06/2013
Erstprüfung: 2013-07-10

Germanischer Lloyd

Hans-Joachim V...

Validity:

www.tuv.com

DGA-ZM-58-95-00

IAF

Certificate number
In accordance with

Your order: 98852
Your order date: 27-09-2013
Your reference: Dimin Rytten

Invoicing address
Customer ref.: 10036
Customer: ITW Welding Product
Address: P. O. Box 1851

3290
LD David Ballester
The Netherlands
Contact: Dimin Rytten
Phone: +31 186 64 148
Email: dr@itw.com

Delivered product

Description: SWX 125
Item no.: 050226
Lot no.: 131408
Quantity kg: 50

Particle size
Cumulative

2.0 mm 0%
4.0 mm 5%6.3 mm 95%10.0 mm 100%

Classification
EN ISO 14174: S A AB 1 57 AC H5

Comments

This product is supplied under a CoA.
This is a computer generated document.
Please refer any queries to:
SWELDX AB, Box 2246, S-400 02, Sweden
Anna Cymus
Quality Manager

CERTIFICATE

Approval of a manufacturer of Welding Consumables
VdTÜV) Appl

TÜVRheinland

on the
Manufacturer of Welding Consumables
Schweißtechnik 1153:01/200

DB Mobility Networks Logistics

Zulassung für
Schweißzusätze und S...

Hersteller: SWELDX AB
Sjajo Kullegata 11
42133 Västra Frölunda
Schweden

Schweißzusatz:
Schweißpulver
Schweißzusatz:
Schweißpulver
SWELDX 120
DIN EN ISO 14174-S A AB 1 57 AC H5

Herstellernummer:
12401.00
06.12

Zulassung nach
VA 918 490 durch...

VdTÜV-Kennblatt für Schweißzusätze

1	Hersteller/Lieferer SWELDX AB S 400 95 Göteborg, Schweden	2	Kennblatt- Nummer: 12401.00 06.12
3	Schweißzusatz: Draht-Pulver-Kombination	6	Pulvermarke: SWELDX 120
4	Marke: SWELDX S 2	9	Pulvertyp: DIN EN 760 - SA AB 157 AC H5
7	Typ: DIN EN ISO 14171 - S2	10	Pulverkörnung: 0,1 - 1,6 mm
13	Die weitere Gültigkeit wird in der jeweils letzten Ausgabe der CD-ROM 'TÜV-eignungsgeprüfte Schweißzusätze' bescheinigt.		
15	Wärmebehandlung (Wb) nach dem Schweißen und Werkstoffe		
Pos		Gruppe / Werkstoff	
I		Gruppe 1	
II		Gruppe 2	
16		Die Werkstoffteilung entspricht ISO 15608:2000	
19		Falls unter 32 nicht anders angegeben, ist die Eignungsprüfung in Position waagrecht gültig.	
20		Drahtdurchmesser/ Bandmessungen [mm]	Stromstärke [A]
		4,0	580
			Spannung [V]
			29
			Gerätevorschub [cm/min]
			55
			Arbeitstemperatur [°C]
			150 - 200
22		Draht-Pulver: Nahtaufbau geeignet für: -Mehrlagenschweißung	
23		Wanddicke: unbegrenzt	
26		Höchste Betriebstemperatur im Kurzzeitbereich wie Grundwerkstoff, jedoch max.:	
27		Höchste Betriebstemperatur im Langzeitbereich wie Grundwerkstoff, jedoch max.:	
28		Tiefste Betriebstemperatur im Kurzzeitbereich wie Grundwerkstoff, jedoch max.:	
29		Berechnungskennwert: wie Grundwerkstoff	
30		Bei Einsatz im Langzeitbereich: wie Grundwerkstoff	
31		Korrosionsbeständigkeit nachgewiesen nach: ---	
32		Bemerkungen:	
33		Die Eignungsprüfung erfolgte auf der Grundlage des VdTÜV-Merkblattes 1153. Soweit in Rubrik 32 - Bemerkungen - nicht anders angegeben, ist dieser Schweißzusatz unter Beachtung des Anhangs I Abschnitt 4 der Druckgeräterichtlinie geeignet.	
34		Erläuterungen: A - angelassen L - lötlingsgeglüht U - abgeschreckt N - normalgeglüht S - spannungsarmgeglüht St - stabilgeglüht U - ungeglüht V - vergütet W - weichgeglüht	
35		Erstellt durch: TÜV Rheinland Group	

Vertrieb: TÜV-Media GmbH, Am Grauen Stein, 51105 Köln - Unternehmensgruppe TÜV Rheinland Group

Herausgeber: Verband der TÜV e.V.

41

Packaging Solutions

Flux

Hobart provides fluxes with maximum security related to weld integrity. Hydrogen in the weld metal is the greatest threat to weld integrity. Elevated levels of moisture in the flux must be avoided at any cost. Since fluxes are hygroscopic, re-drying is generally recommended. The results of re-drying depends on the use of proper drying parameters and on moisture control. The parameters recommended by flux producers do not generally restore original moisture levels. Consequently, prevention of moisture pick-up is extremely important.

In order to protect the flux against moisture pick-up from the air during storage and transportation, Hobart applies moisture-proof packaging as standard.

Packaging — EAE bag

For the standard weight bags, the Hobart solution is a rigidly welded five-layer polyethylene-aluminium foil bag. The packaging material is resistant to any H₂O transfer. In addition Hobart applies EAE (Excess Air Evacuation). Each bag passes a process where excess air is evacuated, creating a reduced pressure atmosphere in the bag. As a result moisture pick-up is drastically reduced and products stored un-opened can be used without re-drying.

Packaging — DoubleBag™

The Hobart solution for bulk packaging is a polypropylene outer bag with an inside polyethylene-aluminium lining. The packaging material is resistant to any H₂O transfer. After filling, the opening is welded. The moisture properties of the DoubleBag are basically the same as for the EAE bag. Moisture-pick up is drastically reduced and products stored un-opened can be used without re-drying.

The bottom of the DoubleBag features a 400 mm (16") long discharge spout, equipped with a locking device to easily control and stop the flow of flux.

Two major user benefits

1. Dry flux means safe welding. The elimination of moisture pick-up makes (possibly ineffective) re-drying redundant and ensures moisture close to the levels as produced.
2. Re-drying is a costly procedure considering the administration, energy consumption, operator handling and equipment investment involved. Its elimination from the production chain saves money and time, while supporting the environment by reducing emissions from energy consumption. Moreover, there is no risk of increasing the dust content by handling the flux in a re-drying process.

Finally, the effectiveness of re-drying depends highly on the process. When the re-drying temperature is too low or when the flux stays too short in the oven, the moisture level may not be lowered sufficiently. This is difficult to determine, as sophisticated laboratory equipment is required to test the actual moisture level of the flux.

Wires

Hobart wires are supplied in accordance with the market requirements. Hobart has defined a standard range of spools and weights, where the target is to always supply off the shelf. In addition Hobart wires are available in different special packaging executions for specific customer needs.



Storage and Handling Recommendations

Hobart SubCOR™ cored wires and SDX solid wires for Submerged Arc welding

The following recommendations are valid for SubCOR and SDX solid submerged arc wires.

Storage and handling recommendations:

- Store wires under dry conditions in the original sealed packaging.
- Avoid contact between wire and substances such as water or any other kind of liquid or vapor, oil, grease or corrosion.
- Do not touch the wire surface with bare hands.
- Avoid exposure of the wire below dew point.
- Store the wire in its original plastic bag and box when not used.
- Apply first-in/first-out for stocked wires.

Hobart fluxes for Submerged Arc welding

All Hobart fluxes are packed in moisture-proof bags. The fluxes are dry and capable of giving a weld metal hydrogen content below 5 ml/100 g without costly (and possibly ineffective) re-drying. This can be achieved when fabricators take necessary actions to prevent pick-up of hydrogen by the weld metal from sources other than the welding consumables.

The following standard Hobart moisture-proof welding flux packaging types are available:

- Hobart 20, 22.7 or 25 kg (44, 50 or 55 lbs) EAE (Excess Air Evacuation) flux bags consisting of a five-layer laminate with an impermeable aluminium foil. The bag weight depends on the flux type.
- Hobart DoubleBag™ up to one ton, lined with an impermeable aluminium foil.

The following storage and handling procedures are recommended to maintain Hobart fluxes in their original dry condition or to re-dry fluxes that may have absorbed moisture:

- Hobart welding fluxes in their original moisture-proof packaging can be safely stored for a maximum period of five years. Make sure that the packaging cannot get damaged.
- In case the original moisture-proof packaging gets damaged, flux shall be re-packed in sealed containers and stored under controlled climatic conditions of 15–35°C (60–95°F) and maximum 70 percent relative humidity, for a maximum period of one year.
- At shift end, flux from unprotected flux hoppers and from opened packs shall be stored in a drying cabinet or heated flux hopper at 150°C ± 25°C (300°F ± 45°F).
- During continuous welding operations, unused flux can be recycled and returned to the flux hopper for reuse. Maintain compressed air in the recycling system, free from moisture and oil. Remove slag and mill scale from the recycled flux. Add at least one part of new flux to three parts of recycled flux.
- For hydrogen critical applications, any flux suspected of having picked-up hydrogen must be re-dried at a temperature of 300–350°C (570–660°F) for a minimum of two hours. Re-drying time starts when the entire quantity of flux has reached 300°C (570°F). Re-dried flux must be stored at 150°C ± 25°C (300°F ± 45°F) before use.



Full-Performance Submerged Arc Welding Pays Back

Successful Submerged Arc welding is not restricted to choosing the correct flux and wire to achieve the required mechanical properties, but also deals with setting up the process in the best possible manner to leverage the investment optimally. Below, we will show examples of Submerged Arc process optimization and the benefits it brings to fabricators. To understand these, it is first needed to define the different cost components. Together they make up the basic cost structure of any manufacturing company.

Cost component	Abbreviation	Examples of cost included
Direct material	DM	Raw materials, components, packaging material, material losses in the process such as scrap.
Variable overhead	VOH	Energy costs for manufacturing process, process consumables, wear parts, cost of temporary workers.
Variable cost	VC	The sum of DM+VOH. Also called direct costs as they are zero if nothing is manufactured.
Direct labor	DL	Wages or salaries, social charges, work clothes, production bonuses, free meals, transport to and from work etc. for blue collar operators in the work shop.
Fixed overhead	FOH	Rental of premises, leasing of equipment, white collar personnel including production management, indirect blue collar personnel such as truck drivers and repair men, costs for heating and lighting, connection fees for utilities and communication. Sometimes also called period costs.
Capital costs	CCC	Capital costs for equipment, owned premises. Typically both calculated interests and depreciation are included.
Manufacturing cost	MC	Sometimes denominated fully absorbed manufacturing costs.
Sales and administration	SG&A	Sales and Administration, typically abbreviated S&A or SG&A. General Management, Sales, Accounting, Logistics, R&D, Engineering etc. Everything from salaries to company cars, from office stationeries to outbound transport costs.
Total cost	TC	Also called cost of goods sold.

Direct labor (DL)

DL is traditionally considered a direct cost, but in reality it is not possible to influence short-to-medium term for the vast majority of companies. Therefore direct labor is regarded as a fixed cost in the Hobart benefit assessment.

Variable contribution

Variable contribution = revenue – direct costs. This is a key measurement, as it tells how much the sales of an item contribute to cover fixed overheads. Because fixed costs in principle do not change with the sales volume, one could argue that the incremental variable contribution is all profit, as soon as the total fixed costs have been covered. When the concept “variable margin” is used, it means the variable contribution as a percent of the revenues.

Impact of welding

Welding consumables for Submerged Arc joining typically stand for between 0.5–2 percent of the total cost of the welded object. However, with a less feasible choice of consumables or setup of the welding process, the impact on manufacturing cost will be far higher than this.

During our efforts to support our clients with Submerged Arc process optimization, we have achieved significant improvements with productivity gains of over 20 percent. When welding is the bottleneck, selling the additional capacity significantly improves the profit.

The diagram on the right is based on what we would call typical distribution of the costs and revenues for companies working with Submerged Arc welding of mild and low-alloyed steels. Based on our experience the majority of companies will not be too far off from this estimation.



In the chart we have set the start-up output at 100 and the invoiced sales price at 100, and split the latter up in three portions:

1. Variable cost stands for 40% of the revenue.
2. Fixed overhead related to manufacturing accounts for 35% of the revenue and fixed sales and administration overhead stands for 15% of the revenue, i.e. in total 50% fixed costs before productivity improvement.
3. A starting balance of 10% profit.

At 10% net increase in output, the company will have to spend 10% more on variable costs (i.e. material, energy etc. as mentioned above), whereas the fixed overheads basically remain unchanged. At this typical distribution between direct and fixed costs the profit will increase by 60% from 10 to 16 and the operating margin will go from 10% to 14.5%!

Miller and Hobart have the intention to support clients to improve productivity and quality. All businesses are different. Hence an individual assessment has to be conducted to identify the potential. Sometimes it is possible to come up with improvements with the same leverage as above, sometimes the result is mainly savings in the direct cost area. Here is a real example of what such activities could mean to a client in monetary terms:

Company:	Spiral pipe mill	
Action	<ul style="list-style-type: none"> • Change of flux to Hobart SWX 135 and change of wire setup • Traveling speed increased by 18% from 2.0 to 2.4 m/min (79 to 94 inches/min) • Net cycle time improvement of 9.6% 	
Output of pipes before improvement	150,000 metric tons per annum	330,000 lbs per annum
Output of pipes after improvement	164,400 metric tons per annum	361,680 lbs per annum
Increased output	14,400 metric tons per annum	361,680 lbs per annum
Difference	9.6%	
Operating margin before improvement	9.9%	
Operating margin after improvement	14.1%	
Improved operating income in relation to flux consumption	14.87 EUR/kg flux used	8.10 USD/lb flux used
<p><i>This case involves a company being in the fortunate situation where demand is higher than their output capabilities. Hobart regards the outcome of the work done in co-operation with the client quite successful, with an improvement of the operating margin by 4.2%-units. To express the value in another sense, it accounted 14.87 EUR/kg (8.10 USD/lb)* for every kg (lb) of flux consumed in the pipe manufacturing.</i></p> <p><i>*Reference of 1.2 USD per EUR currency conversion.</i></p>		

It is our objective to be not only a supplier of welding consumables and equipment, but to support our clients in improving their total welding operations. Aware that our customer's success equals our own, we regard this a continuous effort to be repeated frequently.

HOBART SubCOR™ Cored Wires for Submerged Arc Welding

The use of SubCOR flux-cored wires in Submerged Arc welding provides interesting options that influence weld metal chemistry and thereby microstructure and mechanical properties of the weld. In the same way as Submerged Arc welding fluxes, the flux formulation of these wires promotes a microstructure with a low level of inclusions. This translates in superior low-temperature impact toughness. A high crack resistance is further promoted by the

combination of very low-hydrogen weld metal and a favorable, fine microstructure of mainly acicular ferrite. An example is SubCOR SL 731, a basic cored wire for the Submerged Arc welding of non-alloyed and fine-grain steels. When used in combination with a universally applied low-basicity flux, such as SWX 110, it yields superior low-temperature impact toughness over S2Mo-EA2 solid wire, at comparable yield strength levels (Table 1).

Typical mechanical properties in the as welded condition obtained with universally applied welding flux SWX 110									
Product name	EN	AWS	Cond.	Rp 0.2		Rm		CVN	
				(MPa)	(ksi)	(MPa)	(ksi)	(J)	(ft-lbf)
								-40°C	-40°F
SDX S2Mo-EA2	S 46 2 AB S2Mo	F7A4-EA2-A2	AW	510	74	590	85	35	26
SubCOR SL 731	S 46 4 AB T3		AW	490	71	600	87	115	85

Table 1

Another example is SubCOR SL 742, a cored wire for the Submerged Arc welding of high-strength steel for low-temperature service. When used with SWX 150, a high-basicity flux for demanding multi-layer applications, it gives comfortable safety margins for impact toughness at

low-temperatures compared with its solid wire equivalent SDX S3Ni2.5CrMo (Table 2). The same is valid for SDX CrMo1-EB2R solid wire and SubCOR SL P11 in the creep-resistant range.

Typical mechanical properties in the as welded condition obtained with high basic flux SWX 150									
Product name	EN	AWS	Cond.	Rp 0.2		Rm		CVN	
				(MPa)	(ksi)	(MPa)	(ksi)	(J)	(ft-lbf)
								-60°C	-76°F
SDX S3Ni2.5CrMo	S 69 6 FB S3Ni2.5CrMo		AW	710	103	800	116	55	40
SubCOR SL 742	S 69 6 FB T3 Ni2.5CrMo	F11A8-ECF5-F5	AW	720	104	820	119	100	74
								-20°C	-4°F
SDX CrMo1-EB2R	S S CrMo1 FB	F8P2-EB2R-B2	SR	490	71	620	90	100	74
SubCOR SL P11	S T CrMo1 FB		SR	510	74	600	90	200	147

Table 2

Additional benefits of SubCOR SL type cored wires

- A higher safety margin on low-temperature impact toughness.
- Weld metal hydrogen <4 g/100 ml can be reached.
- Totally insensitive for moisture pick-up, regardless of climatic conditions.
- No special storage requirements. Can be stored as solid wires.
- Improved current transfer from contact tip, due to copper coating.
- Low contact tip wear.
- Greater crack resistance due to a favorable rounded bead shape with reduced depth-width ratio.
- Wide cast, low helix and moderate stiffness give consistent wire feeding and straight wire delivery from the contact tip.
- Available for a wide range of non- and low-alloyed steel grades.

Steel category	Hobart SubCOR™ cored wire	Application
Unalloyed	SL 731	General purpose AW/SR
	SL 840 HC	Mech. engineering, pipelines, vessels AW/SR/N/N+A
	SL 735-1W-5W	Single run/two run
High-strength	SL 741	Re 315-550 MPa AW/SR
	SL 742	Re >690 MPa AW/SR
	SL 745	Re > 890 MPa AW
Weather-resistant	SL 281 Cr	Re 255 - 460 MPa
Creep-resistant	SL P1	0.5Mo, P1
	SL P1 MOD	0.5Mo + V (14MoV6-3)
	SL P11	1.25Cr/0.5Mo, P11
	SL P12 MOD	1.00Cr/0.5Mo, P12
	SL P36	0.5 Mo, P36
	SL P22	2.25 Cr/1Mo, P22
	SL P24	2.5Cr/1Mo +V, P24
	SL P5	5Cr/0.5Mo, P5
	SL P9	9Cr/1Mo, P9
	SL P91	9Cr/1Mo + Nb, V, P91
SL P92	10Cr/1Mo + V, W, P91	

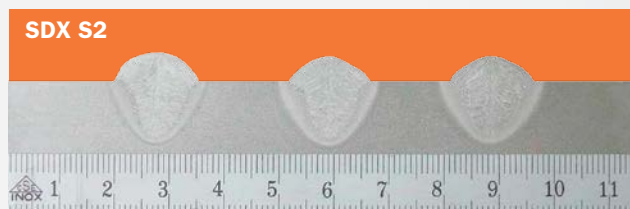
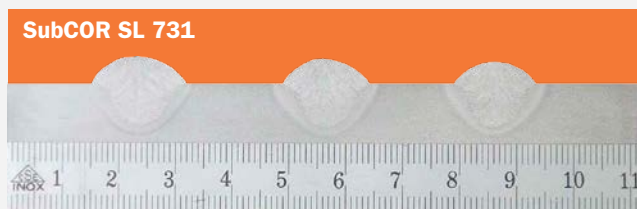

Difference in weld profile between SubCOR SL 731 cored wire and S2 solid wire SDX S2. The cored wire gives a more crack-resistant rounded bead shape with reduced depth-width ratio. Welded with SWX 120 at 600 A and 25 mm (1") stickout length. Wire diameter 2.4 mm (1/10").

Improved Productivity from SubCOR™ Metal-Cored Wires

SubCOR metal-cored wires for Submerged Arc welding offer a number of advantages over the use of solid wires — in terms of welding efficiency, weldability and weld quality.

- Potential for higher deposition rates than solid wires at the same amperage.
- Potential to increase deposition without increasing heat input, or to decrease heat input without sacrificing deposition.
- Often better impact toughness and CTOD properties.
- A more favorable, broader shaped penetration and fusion pattern.
- Greater tolerance to gaps, poor fit up, and burn through.

Metal-cored wires are composite tubular electrodes consisting of a metal sheath and a core of metallic and/or non-metallic ingredients. An example of a metallic ingredient is iron powder. The deposition efficiency will increase with the amount of metallic ingredients in a composite tubular wire. Non-metallic ingredients can, for instance, be agents that clean and deoxidize the weld or slag forming components. In a metal-cored wire, the current travels almost exclusively through the sheath,

whereas in a solid wire the current travels through the entire cross-section of the wire (Figure 1). Therefore, at an equivalent amperage setting, a metal-cored wire will experience higher current densities. The resulting increased melt-off rates, in combination with a high percentage of metallic particles, offers increased deposition rates. The effect is most prominent at higher welding currents (Figures 2 and 3).

Current path through solid and metal-cored wires

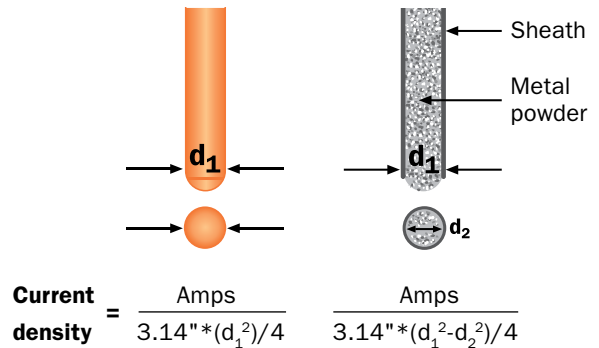

Figure 1

3.2 mm (1/8") diameter wire comparisons (DCEP)

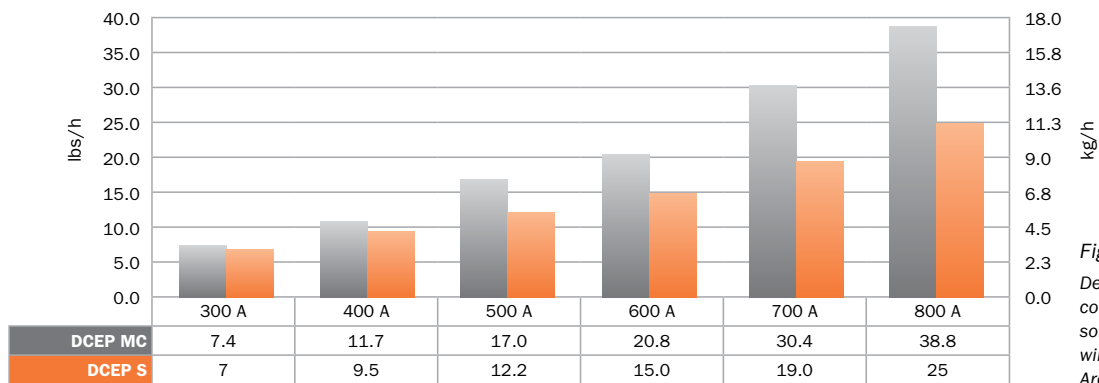

Figure 2
Deposition rate comparison between solid and metal-cored wires for Submerged Arc welding.

4.0 mm (5/32") diameter wire comparisons (DCEP)

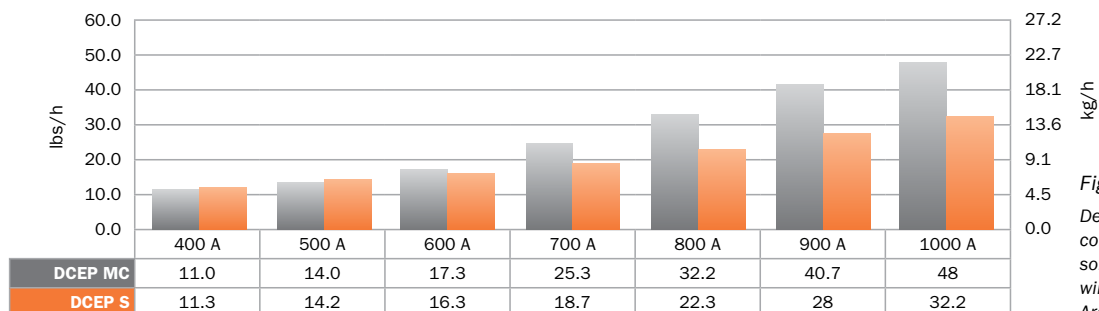

Figure 3
Deposition rate comparison between solid and metal-cored wires for Submerged Arc welding.

The following data results from a qualification test performed in offshore fabrication. The steel used was an offshore grade with a minimum yield strength of 460 MPa (67 ksi) in 32 mm (1.25") plate thickness. The joint preparation was a 60° V-joint. The root pass was done by GMAW with an S2Ni1-ENi1 solid wire. For the Submerged Arc welding, variable balance power sources were used in a triple-wire setup.

	Metric		Imperial		MC vs Solid
	Solid wire	Metal-cored wire	Solid wire	Metal-cored wire	
Submerged arc wire	Hobart SDX S3Ni1Mo.2-ENi5	Hobart SubCOR™ 92-S	Hobart SDX S3Ni1Mo.2-ENi5	Hobart SubCOR™ 92-S	
Flux	Hobart SWX 150	Hobart SWX 150	Hobart SWX 150	Hobart SWX 150	
Wire class EN ISO 14171/ AWS A5.23	S3Ni1Mo.2/ENi5	—/ECM1	S3Ni1Mo.2/ENi5	—/ECM1	
Wire setup	3 x 4.0 mm	3 x 4.0 mm	3 x 5/32"	3 x 5/32"	
Process description	AC/AC/AC	AC/AC/AC	AC/AC/AC	AC/AC/AC	
Parameters	30–35 V, 550–700 A	28–36 V, 600–700 A	30–35 V, 550–700 A	28–36 V, 600–700 A	
Wire feed speed	125–190 cm/min	190–250 cm/min	50–75 inch/min	75–100 inch/min	
Travel speed	107 cm/min	120 cm/min	42 inch/min	47 inch/min	+12%
No. of passes	12	11	12	11	-1
Max interpass temperature	260°C	260°C	500°F	500°F	
Peak heat input	3.3 kJ/mm	3.2 kJ/mm	84 kJ/inch	82 kJ/inch	
Average heat input	3.1 kJ/mm	3.0 kJ/mm	79 kJ/inch	77 kJ/inch	
AW yield strength	497 MPa	490 MPa	72.1 ksi	71.1 ksi	
Cross weld tensile	500 MPa	498 MPa	72.6 ksi	72.1 ksi	
CVN @ -40°C (-40°F) — Root	102 J	103 J	75 ft-lbs	76 ft-lbs	
CVN @ -40°C (-40°F) — Cap	88 J	121 J	65 ft-lbs	89 ft-lbs	+37%
CTOD @ -10°C (+14°F)	1.27 mm	1.61 mm	0.050 inch	0.063 inch	
Deposition rate	24.9 kg/h	30.6 kg/h	54.8 lbs/h	67.3 lbs/h	+23%

This case represents well the difference between a metal-cored and a solid wire in a 4.0 mm (5/32") wire diameter application. You will typically see both a productivity gain as well as improved mechanical properties. Productivity is, of course, always important in any business. Metal-cored wires provide this. However, sometimes the required mechanical properties are the limiting factor and, in most cases, these can be met by exchanging solid to MC wires, without sacrificing productivity. There are also cases, mainly in high-strength and high-temperature applications, where the mechanical properties cannot be met without exchanging the solid wire with a cored wire.

Estimating deposition rates for metal-cored and solid wires

An efficiency of 99% is used when calculating the deposition rates of solid wires when used in the Submerged Arc (SAW) process. In comparison, metal-cored wires use a 97% efficiency rate for calculating deposition rates, whereas efficiency rates of 92% can be realized with flux-cored wire. It should also be noted that metal-cored wires for SAW are formulated differently than those metal-cored

wires formulated to run with shielding gas. They show differences in deposition efficiency, as well as in the weight of the wire. By using the numbers below one can create a simple spread sheet to calculate deposition rates based off of wire feed rates and deposition efficiency.

Net weld metal deposition for metal-cored and solid SAW wires				
Efficiency	MC 97% efficiency		Solid 99% efficiency	
Wire weight	g/m		lbs/inch	
Wire diameter	MC	Solid	MC	Solid
2.4 mm (3/32")	30	35	0.0017	0.0020
3.2 mm (1/8")	50	60	0.0028	0.0034
4.0 mm (5/32")	80	95	0.0045	0.0053

Table 1

Approximate deposition rate:

Wfs = Wire feed speed cm/min (inches/min)

Metric: Deposition rate kg/h =

Wire weight g/m * Wfs cm/min * 0.0006

Imperial: Deposition rate lbs/h =

Wire weight lbs/inch * Wfs inches/min * 60

Flux-Cored Micro Injection

Flux-Cored Micro Injection (FMI) is a special application of Hobart SubCOR™ SL cored wires. In single- and two-run welding, micro-alloying through the cored wire is an effective way to counteract the formation of a coarse microstructure and to promote good impact toughness. In single- or two-run applications, recrystallization by subsequent layers does not occur, or not to the same extent as with multi-layer welds. As a consequence, the microstructure maintains its solidification structure with high amounts of coarse ferrite and limited impact toughness. Micro-alloying through the core of flux-cored wires, provides nuclei in the solidifying weld metal that act as initiation points for a fine microstructure of favorable acicular ferrite giving high impact toughness. Typical single- and two-run applications are found in the welding of ship panels and in the production of line pipe in pipe mills. For productivity reasons, multi-layer welds are

avoided as much as possible and as high as possible plate thickness is covered with the single- or two-run techniques, mostly with multi-wire welding heads. Flux-Cored Micro Injection with SubCOR SL cored wires are developed to give good weld metal impact toughness in such applications.

SubCOR SL 735 -1W (1 wire) is developed for single-wire welding. Increasing levels of micro-alloying are applied in the multi-wire versions — 2W, 3W, 4W and 5W — which are developed respectively for two-, three-, four- and five-wire welding. It is important to note that only a single cored wire is needed in multi-wire applications to obtain the desired effect. With the 2W, 3W, 4W and 5W versions, cored wire formulations are adapted to obtain the same weld chemistry as with the 1W version. All other wires on the same welding head are standard solid wire types.

The benefits of FMI applied in high-deposition Submerged Arc welding are:

- A finer microstructure and associated higher weld metal impact toughness.
- Thicker plate thicknesses can be covered.
- Good weld metal impact toughness is maintained at higher deposition rates.

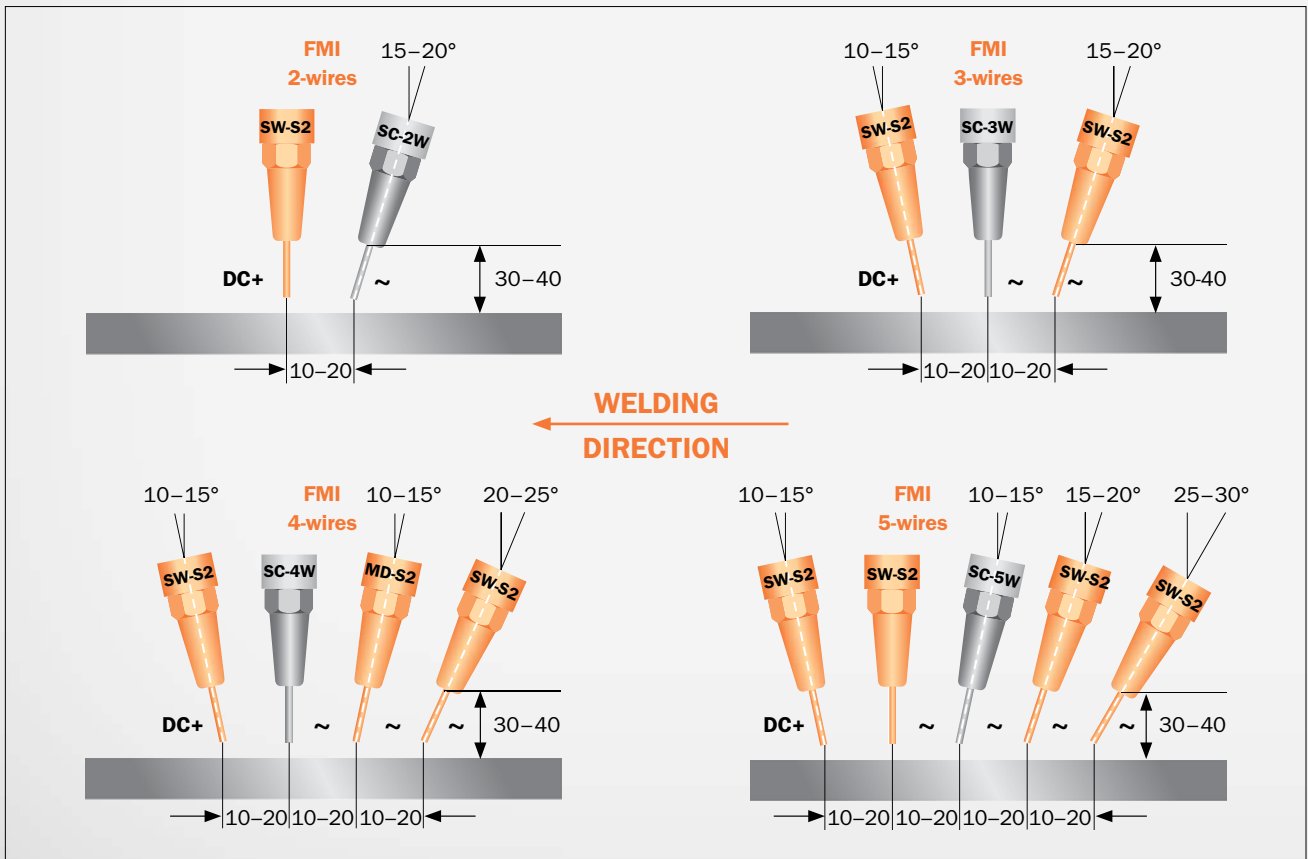

Position of wire electrodes and welding heads in the FMI process. SW: solid wire. SC: SubCOR. Measurements are in mm.

Macro cross section, impact toughness values

CVN (J)	0°C	-20°C	-40°C	-60°C
1st layer (bottom)	156	132	75	52
2nd layer	165	153	126	88
CVN (ft-lb)	32°F	-4°F	-40°F	-76°F
1st layer (bottom)	115	97	55	38
2nd layer	122	113	93	65

Macro cross section of a two-run weld in 22-mm thick plate welded with a three-wire system: 2 x SDX S2Mo-EA2 and 1 x SubCOR 735 -3W. Travel speed 1st layer: 90 cm/min (35"/min). Travel speed 2nd layer: 130 cm/min (51"/min). Impact toughness values are average of three.

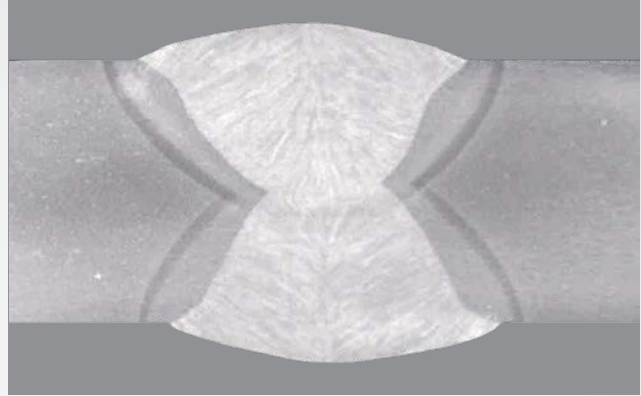

Flux-Cored Micro Injection (FMI) applied in the welding of X65 line pipe for sour gas service

FMI has been successfully applied in the production of 685,000 metric tons of longitudinally welded large diameter line pipe for sour gas service. This involved material grade X65, in wall thicknesses of 19.05 and 25.4 mm. The CVN impact requirement was 85J at 0°C. SubCOR™ SL 735 -4W was combined with three S2Mo wires in a four-wire welding head. The table shows the welding parameters applied in the two-run technique for welding 25.4-mm (1") thick X65 grade pipe.

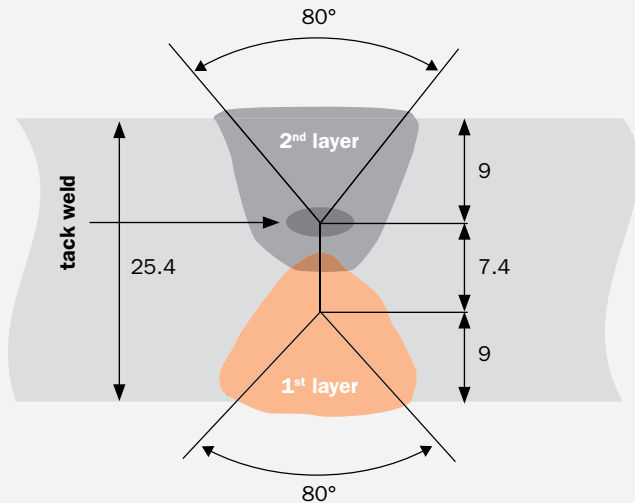

FMI process parameters for a sheet thickness of 25.4 mm (1").

2 nd layer	All wires in Ø 4 mm	1 st head S2Mo	2 nd head 735 -4W	3 rd head S2Mo	4 th head S2Mo
	Current [A]	1150	900	800	750
Voltage [V]	35	38	38	40	
Speed [cm/min]	155 (61"/min)				

1 st layer	All wires in Ø 4 mm	1 st head S2Mo	2 nd head 735 -4W	3 rd head S2Mo	4 th head S2Mo
	Current [A]	850	750	650	600
Voltage [V]	35	35	36	37	
Speed [cm/min]	115 (45"/min)				

In total, 25 batches of SubCOR SL 735 -4W were manufactured for the production of 62,000 pipes. In addition to the approval welds, production tests were performed on original X65 for each batch under the same circumstances as in actual production. The diagram shows the statistic evaluation of the CVN impact toughness over 25 batches. The requirement of 85J at 0°C (63 ft-lbf at 32°F) is consistently met with a substantial safety margin for all areas of the weld, including heat affected zone.

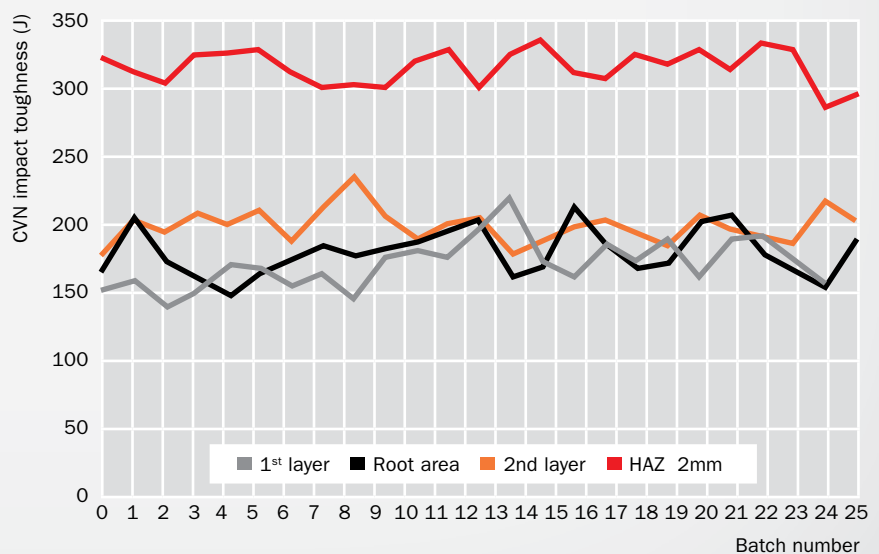

Statistic evaluation of CVN test results. Requirement: 85J at 0°C (63 ft-lbf at 32°F).

Submerged Arc Welding Process

From fundamentals to the latest technology

In Submerged Arc welding (SAW), the arc is “submerged” in flux and is not visible when parameters are correctly set and the layer of flux is sufficiently thick. The wire is automatically fed through a welding head that moves along the weld joint. The arc heat melts a portion of wire, flux and parent metal to form a molten weld pool. In this area all important functions of the flux — such as degassing, deoxidizing and alloying — take place. Behind the arc, molten flux and metal freeze to form a slag-covered weld bead.

When the welding process is correctly set the slag should come off without any particular effort. The process is normally mechanized or automated. Key components of the process welding head, flux feeding and recovery system, wire spool, wire feeders and control unit are mounted on a carrier such as a tractor or column and boom. Power sources are usually positioned anywhere near the carrier, along with bulk wire supply.

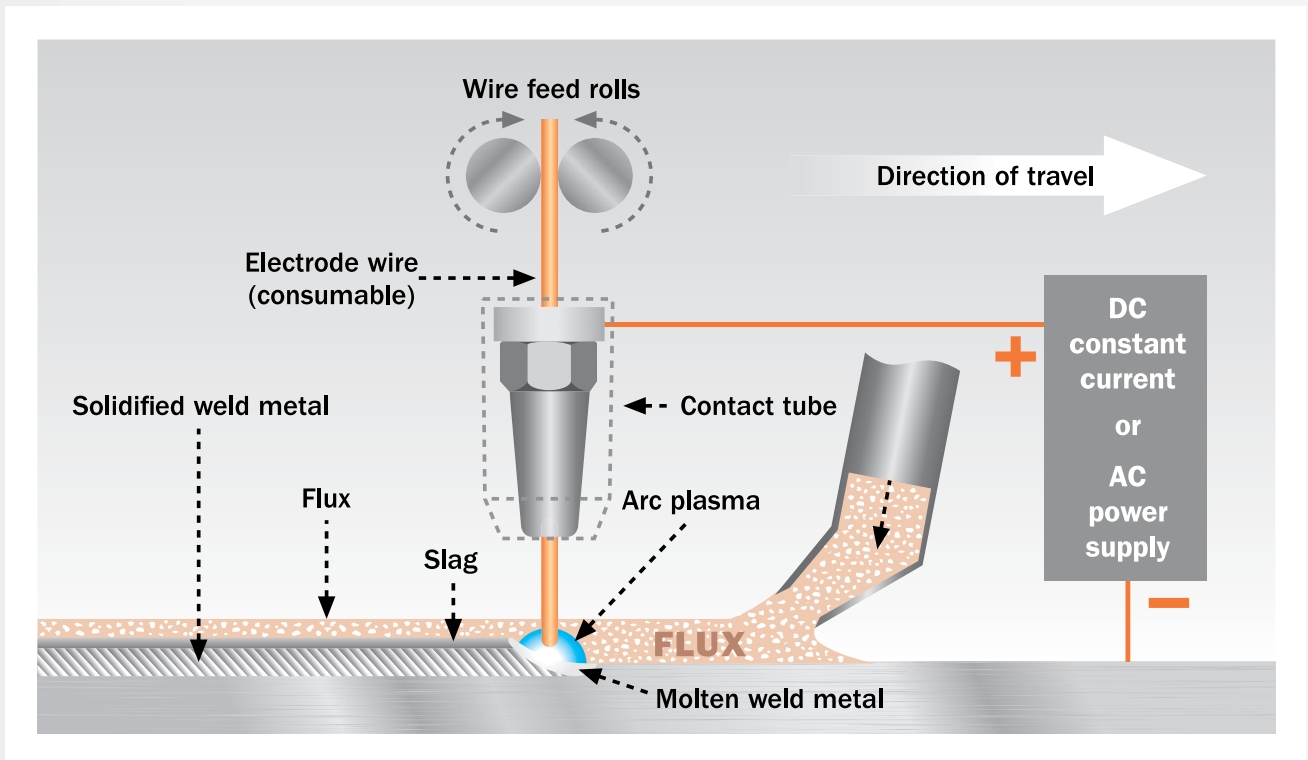

Single-wire Submerged Arc welding



1. Power source
2. Welding head
3. Flux hopper
4. Control unit
5. Wire spool
6. Carrier
7. Manipulator

Miller and Hobart as First Tier Members, have installed an advanced Miller SAW and ESW welding and strip cladding system at the Nuclear AMRC (Nuclear Advanced Manufacturing Research Centre) in the UK. The equipment has enabled both organizations to carry out research and development work in advancing the SAW process for nuclear, renewable energy and oil and gas related projects.

Submerged Arc Welding Process

Pros and cons of the process

Submerged Arc welding has a number of distinct advantages in terms of welding economy and weld quality, but also some limitations compared with other arc welding processes.

Advantages:

- Clean automatic process without UV radiation and spatter and minimal fume.
- Superior deposition rates of up to 100 kg/h (220 lbs/h) in multiple-wire welding.
- Very high travel speeds of up to 250 cm/min (100"/min).
- From a few millimeters to unlimited plate thickness.
- Excellent mechanical properties and X-ray quality welds.
- No spatter — high weld metal recovery.
- Reliable process with secure weld penetration and reduced risk of lack of fusion.
- Weld metal chemical composition and mechanical properties can be controlled via the flux/wire combination.

Limitations:

- Capital investment.
- Only suited for flat groove (1G) and horizontal fillet positions (PA/1F, PB/2F). PC/2G possible with flux support.
- Requires first class joint preparation.
- Requires precise parameter setting and positioning of the wire electrode.
- Adjustments not easily determined because of the invisible arc.
- Requires disposal of the slag.

Welding flux — a critical process component

In Submerged Arc welding, the flux performs a number of essential functions:

- Enables a stable arc at the high welding currents characteristic for this productive process.
- Creation of a slag that forms a cavity for the arc to establish in.
- Improvement of arc conductivity and droplet transfer.
- Shielding droplets, weld pool and solidifying weld from the surrounding air.
- Deoxidization of the weld metal and removal of impurities.
- Supports deep penetration by preventing heat from escaping the weld area.
- Meets different chemical and mechanical weld requirements, depending on the wire electrode.

To enhance the Submerged Arc welding process the flux must:

- Have the right particle mix to allow degassing and facilitate high welding currents.
- Have the right slag properties to allow high-travel speeds.
- Create a slag that releases easily.
- Provide the lowest possible flux consumption.
- Have good grain strength to limit the forming of dust in recycling.

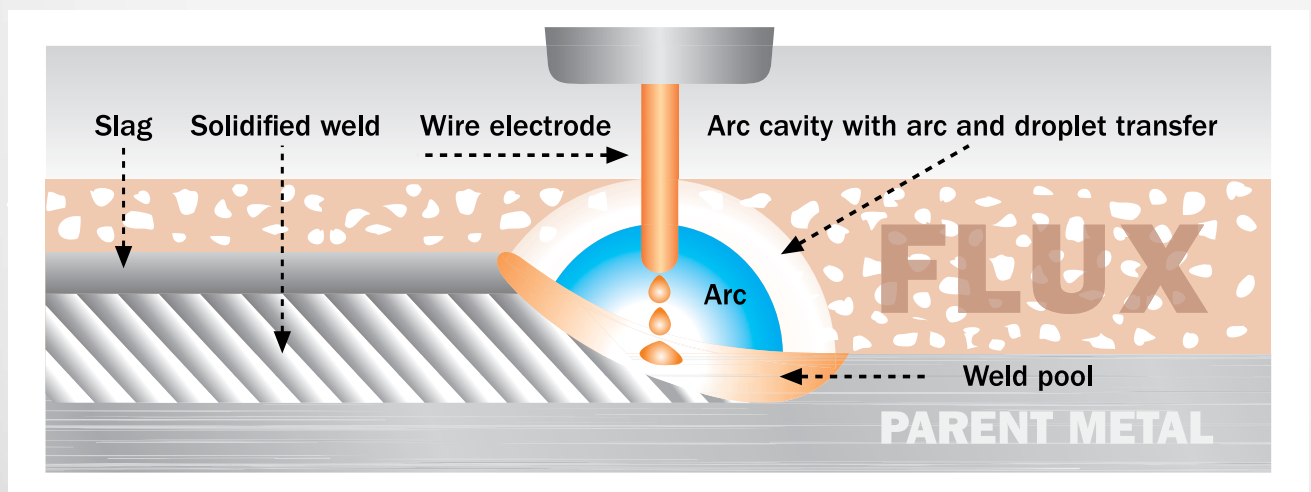

Fluxes for Submerged Arc welding and their manufacturing methods

There are two primary types of welding fluxes characterized by their manufacturing method; agglomerated and fused.

Fused fluxes have long been used universally in Submerged Arc welding, but have widely been replaced by agglomerated fluxes — even in countries with a tradition in the use of fused fluxes.

In the production of agglomerated fluxes, powder raw materials with specified grain size are mixed with a bonding agent to form chemically homogeneous grains. Subsequently, the flux is baked at high temperature to remove moisture and sieved to the desired grain size distribution. Agglomerated fluxes provide the following advantages compared to fused fluxes for the Submerged Arc welding process:

- The lower temperature in the manufacturing process allows addition of a higher level of deoxidizers and alloying elements. This results in cleaner welds with significantly improved mechanical properties; most notably with better low-temperature impact toughness.
- In the vast majority of applications agglomerated fluxes allow higher traveling speed, typically meaning lower manufacturing costs.
- Agglomerated fluxes are available for all steel grades and applications.
- Lower flux consumption as many agglomerated fluxes operate well at lower arc voltages.

Hydrogen classes

The hydrogen class of a flux, as manufactured, is embedded in the classification according to EN ISO 14174, AWS A5.17 and AWS A5.23.

EN ISO 14174: e.g. S A AB 1 67 AC **H5**. H5 indicates that the flux is capable of producing a weld metal with less than 5 ml diffusible hydrogen per 100 g weld metal.

AWS A5.17: e.g. F7A4-EM12K-**H4**. H4 indicates that the flux is capable of producing a weld metal with less than 4 ml diffusible hydrogen per 100 g weld metal.

Hydrogen class		ml/100 g deposited weld metal
EN ISO 14174	AWS A5.17 and AWS A5.23	
	H2	<2
	H4	<4
H5		<5
	H8	<8
H10		<10
H15		<15
	H16	<16

Hobart fluxes and packaging

The Hobart welding fluxes reviewed in this catalog are all agglomerated, low-hydrogen types. The various SWX fluxes, in combination with the appropriate SDX or SubCOR™ wire electrode, cover a wide range of grades within normal-strength, high-strength, low-temperature, creep-resistant and stainless steel, as well as nickel-base alloys. They feature extremely low moisture contents and are all supplied standard in moisture-proof EAE (Excess Air Evacuation) bags or DoubleBag™ bulk packaging, both giving maximum security against moisture absorption and hydrogen cracking.

Flux types and Standards

Fluxes and flux/wire combinations for Submerged Arc welding are named, standardized and categorized in various International Standards, mainly EN ISO and AWS. The standards referred to in this catalog are:

- **EN ISO 14171:**
Solid wire electrodes, tubular cored electrodes and electrode/flux combinations for Submerged Arc welding of non-alloy and fine-grain steels.
- **EN ISO 14174:**
Fluxes for Submerged Arc welding.
- **EN ISO 24598:**
Solid wire electrodes, tubular cored electrodes and electrode-flux combinations for Submerged Arc welding of creep-resistant steels.

Submerged Arc Welding Process

- **EN ISO 26304:**
Solid wire electrodes, tubular cored electrodes and electrode-flux combinations for Submerged Arc welding of high-strength steels.
- **EN ISO 14343:**
Wire electrodes, strip electrodes, wires and rods for arc welding of stainless and heat-resistant steels.
- **SFA/AWS 5.17:**
Specification for carbon steel electrodes and fluxes for Submerged Arc welding.
- **SFA/AWS 5.23:**
Specification for low-alloy steel electrodes and fluxes for Submerged Arc welding.
- **SFA/AWS A5.9:**
Bare stainless steel welding electrodes and rods.

Fluxes are categorized in different ways. Agglomerated versus fused fluxes is one of them, but within these categories there is a variety of flux compositions possible. A refined method is given in the EN ISO 14174 flux classification standard where fluxes are marked with a symbol for their main chemical constituents, for example: S A **AB** 1 67 AC H5

Here **AB** signifies that it is an aluminate-basic flux. The most frequently used symbols are given in the following table together with their main chemical constituents. All relevant EN ISO standards use these symbols to typify the flux within classifications of flux/wire combinations. All relevant classification standards are explained in detail elsewhere in this catalog.

Symbol	Flux type	Characteristic chemical constituents	% of total flux
FB	Fluoride-basic	CaO+MgO+CaF ₂ +MnO	>50
		SiO ₂	<20
		CaF ₂	>15
AF	Aluminate-fluoride-basic	Al ₂ O ₃ + CaF ₂	>70
AB	Aluminate-basic	Al ₂ O ₃ + CaO + MgO	>40
		Al ₂ O ₃	>20
		CaF ₂	<22
AR	Aluminate-rutile	Al ₂ O ₃ + TiO ₂	>40

Flux basicity index (BI)

Basicity is commonly used to describe the relation between basic flux ingredients and acidic flux ingredients.

$$BI = \frac{\% \text{ basic oxides}}{\% \text{ acidic oxides}}$$

The most commonly applied method to calculate the basicity index is according to Boniszewski's formula:

$$BI = \frac{CaO + MgO + SrO + BaO + Li_2O + Na_2O + K_2O + CaF_2 + 0.5 (FeO + MnO)}{SiO_2 + 0.5 (Al_2O_3 + TiO_2 + ZrO_2)}$$

A high basicity index leads to lower oxygen levels and thereby to fewer micro inclusions in the weld metal, which is beneficial for the microstructure and improves impact toughness. However, a higher basicity generally gives a slag with lower viscosity and hence a lower current carrying capacity of the flux, leading to lower productivity. It is recommended to look for the lowest possible basicity flux in order to achieve the required impact toughness.

Basicity index	Type of flux	Weld metal O content (wt.-%)
BI < 0.9	Low basicity flux	> 700 ppm
BI 0.9–1.2	Neutral basicity flux	500–700 ppm
BI 1.2–2.5	Basic flux	350–500 ppm
BI > 2.5	High basic flux	< 350 ppm

Hobart fluxes basicity vs. CVN impact toughness

The diagram below gives a schematic view of the relationship between basicity index of the flux and impact toughness with a given wire. It is also indicated where Hobart fluxes are positioned according to their basicity index.

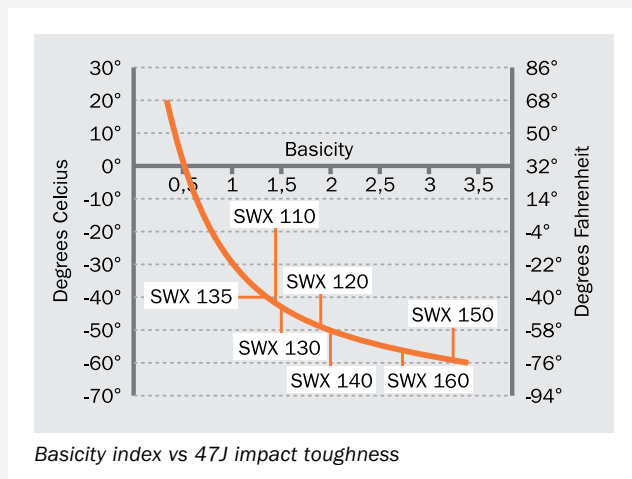

Alloying behavior

EN ISO 14174 classifies the flux according to its pick up behavior of Si and pick-up/burn-off behavior of Mn according to the table below.

Metallurgical behavior class 1 fluxes		
Symbol	Behavior	Contribution from flux
1	Burn-off	0.7–
2	Burn-off	0.5–0.7
3	Burn-off	0.3–0.5
4	Burn-off	0.1–0.3
5	Neutral	0–0.1
6	Pick-up	0.1–0.3
7	Pick-up	0.3–0.5
8	Pick-up	0.5–0.7
9	Pick-up	0.7–
Class 1. Si and Mn alloying		

Si and Mn alloying effects according to EN ISO 14174 determined using S2 wire and welded at standardized parameters of 580 A, 29 V, 55 cm/min.

In the EN ISO 14174 designation S A AB 1 **57** AC H5 the number **57** indicates that this flux is not adding any Si, but adds 0.3–0.5% of Mn under the given circumstances. Si acts as a deoxidizer and makes the weld pool more fluid, while Mn increases weld metal strength and impact toughness.

The higher the number for metallurgical behavior is, the more Si and/or Mn is alloyed through the flux. A high-alloying flux can be beneficial for welding and/or mechanical properties especially in high-dilution applications. However, it must be used with caution in multi-run welds and when using high Si and/or Mn alloyed wires, due to the risk of excessive alloy build up in the weld metal that can lead to deteriorated mechanical properties and an increased risk of cracks. The high-alloying fluxes are also sensitive to welding parameters as the alloying increases with increasing arc voltage.

AWS A5.23 gives an indication of the metallurgical behavior of the flux in the second and third part of the flux-wire designation. F8A2-**EA2** (wire classification)-**A4** (weld metal classification).

AWS also has another way to classify the chemical interaction of the flux and that is the Wall Neutrality Number (N). N is measured by making one weld pad using a specified set of parameters. Then another weld pad is made using the same set of parameters except for arc voltage, which is increased by 9 V. The Mn and Si content of the two weld pads are analyzed and the Wall Neutrality Number is then calculated according to the formula below.

$$N = 100 \times (|\Delta\text{Mn}| + |\Delta\text{Si}|)$$

A flux is considered neutral when having a Wall Neutrality Number of 35 or lower.

Submerged Arc Welding Process

Hobart metallurgical behavior diagrams

For each flux Hobart gives the appropriate classification according to EN ISO 14174 with the two digit identification of metallurgical behavior. In addition, diagrams are provided to show the typical weld metal analyses in relation to the wire analyses for silicon and manganese. Values are determined at both 500 and 800 A to provide guidance.

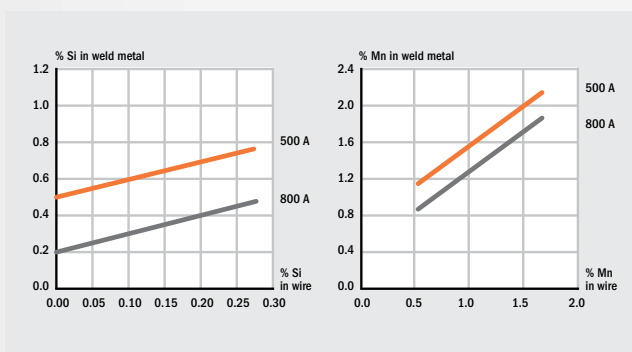

Metallurgical behavior diagram for flux SWX 110, a slightly Si and Mn alloying flux.

Alloying fluxes

Alloying fluxes add chromium, nickel and/or molybdenum to obtain a specific high-alloy weld metal composition when using lower-alloyed wires or strips. Voltage control is important, as it has an influence on the amount of flux taking part in the chemical reaction. Alloying fluxes are mostly applied in stainless and high-alloy cladding applications.

Grain size

Flux grain size is important because it influences current carrying capacity and flux feeding and recovery:

- A correct grain size allows gases to escape from the molten weld pool.
- Grain size determines the current carrying capacity of the flux. Coarser particle size is needed for higher currents.
- For high travel speeds in thin materials a fine-grained flux is preferred.
- Fluxes with excessive high amounts of fine particles could segregate in flux feeding and recovery systems.

Grain size is commonly expressed by a minimum and maximum particle size. The grain size can be expressed either in mm (size of the openings in the sieve cloth in mm) or in mesh (the number of openings/inch in the sieve cloth).

A grain size of 0.2–1.6 mm means that the grains of the flux are larger than 0.2 mm (70 mesh) and smaller than 1.6 mm (12 mesh).

A grain size of 12–70 mesh means that the grains of the flux are smaller than 12 mesh (1.6 mm) and larger than 70 mesh (0.2 mm).

Hobart states grain size in both millimeters and mesh in product data.

Submerged Arc welding process options

Submerged Arc welding even in its simplest form is already a highly productive process. Deposition rates in single-wire welding, the most widely applied method, can amount to 12 kg/h when applications allow the use of large-diameter wires at high welding currents. A variety of process options has evolved over the years with the objective to further increase welding productivity; often developed to meet the challenges of specific industries. The following process options are observed in today's Submerged Arc welding (SAW).

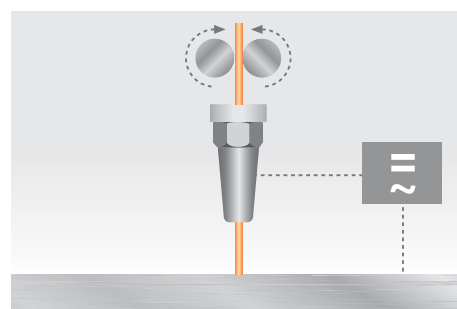

Single-wire SAW

- One wire, one feeder, one welding head
- One power source, one control unit
- Wire diameter 1.6–5.0 mm (1/16–3/16")
- Welding current 200–1000 A
- Generally applied across industries

Deposition rate up to 12 kg/h (26 lbs/h)

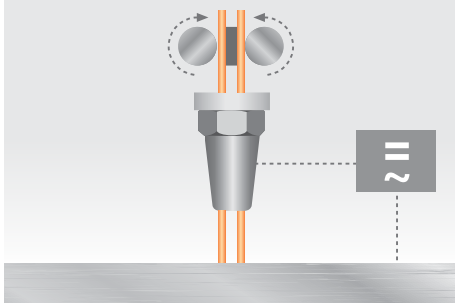

Twin-wire SAW

- Two wires, one 2-roll wire feeder, one 2-wire contact nozzle
- One power source, one control unit
- Wire diameter 1.2–3.2 mm (0.045–1/8")
- Total welding current 400–1200 A
- Generally applied across industries
- Moderate investment to upgrade from single-wire SAW

Deposition rate up to 20 kg/h (44 lbs/h)

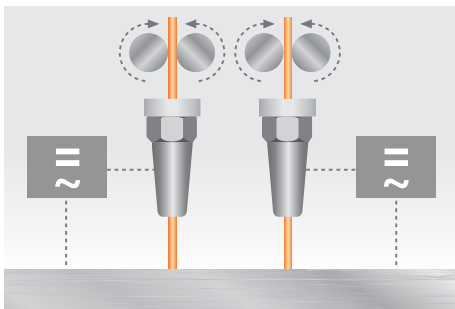

Tandem-wire SAW

- Two wires, two feeders, two welding torches
- Two power sources, two control units
- Wire diameter 3.2–5.0 mm (1/8–3/16")
- Total welding current 1200–2000 A
- Shipbuilding, pressure vessels, heavy beams, bridges, offshore fab.
- Relatively high investment compared to single-wire SAW

Deposition rate up to 25 kg/h (55 lbs/h)

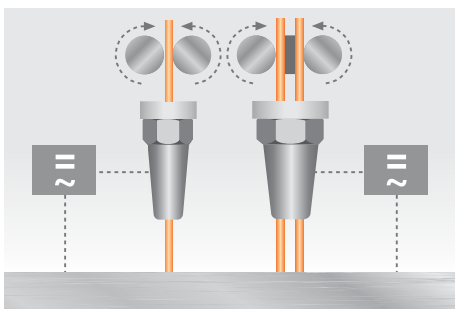

Tandem single-/twin-wire SAW

- Three wires, one 1-roll and one 2-roll feeder, one 1-wire and one 2-wire head
- Two power sources, two control units
- Wire diameter 2.4–4.0 mm (3/32–5/32")
- Total welding current 1100–1700 A
- Wind towers, pressure vessels
- Small incremental investment compared to Tandem SAW

Deposition rate up to 30 kg/h (66 lbs/h)

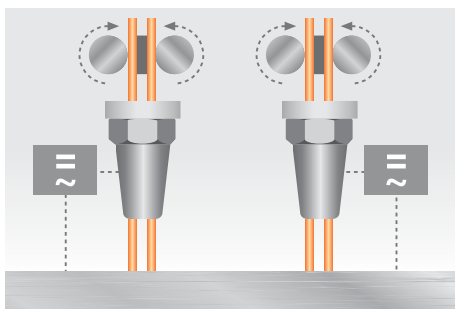

Tandem twin-wire SAW

- Four wires, two 2-roll feeders, two 2-wire heads
- Two power sources, two control units
- Wire diameters 1.6–3.2 mm (1/16–1/8")
- Total welding current 1500–2200 A
- Wind towers, pressure vessels
- Small incremental investment compared to Tandem SAW

Deposition rate up to 35 kg/h (77 lbs/h)

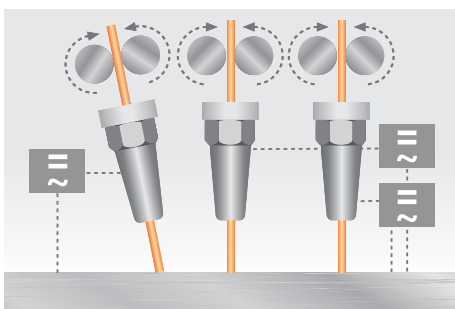

Multi-wire SAW

- Up to five wires, feeders, heads, power sources and control units
- Wire diameters 3.2–5.0 mm (1/8–3/16")
- Total welding current 2000–5500 A
- Pipemills, offshore, shipbuilding
- High investment

Deposition rate up to 100 kg/h (220 lbs/h) with five wires

Submerged Arc Welding Process

Effects of welding parameters

The welding parameters in Submerged Arc welding — arc voltage, welding current, travel speed, stick-out, torch angle, wire diameter, wire feed speed and polarity — all influence the shape and quality of the weld, and productivity. It is important to be aware of their individual and combined influence. In this chapter we do not discuss welding

defects that result from incorrect parameters — mostly set too low or too high. These are discussed in the troubleshooting section of this catalog. These tables review the effects when individual welding parameters are increased, while all other parameters remain unchanged. Decreasing them will have opposite effects.

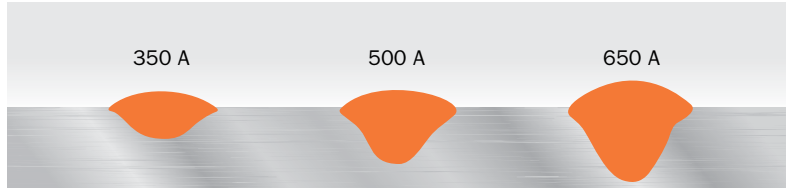
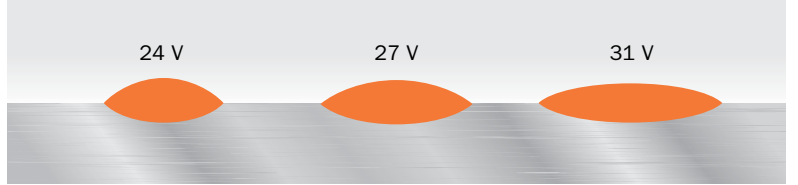
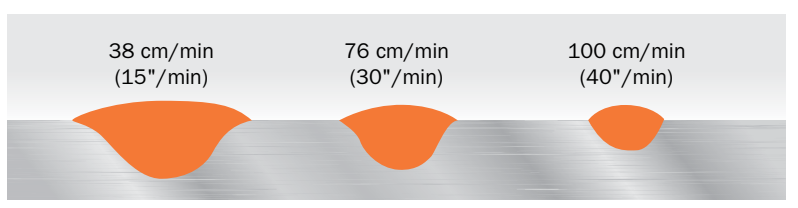
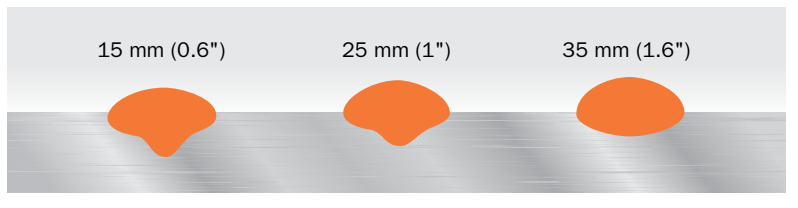
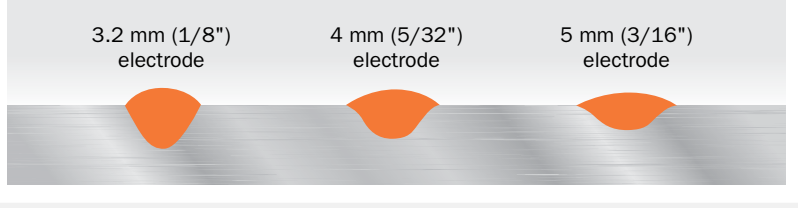
<p>Effects of increased current</p> <ul style="list-style-type: none"> Higher deposition rate Higher heat input Larger heat affected zone Increased penetration Increased bead height Higher dilution with parent metal 	<p>Effects on weld profile</p> 
<p>Effects of increased voltage</p> <ul style="list-style-type: none"> Higher heat input Larger heat affected zone No change of penetration Wider beads, lower bead height Increased flux consumption 	<p>Effects on weld profile</p> 
<p>Effects of increased travel speed</p> <ul style="list-style-type: none"> Lower heat input Smaller beads Less penetration Less dilution 	<p>Effects on weld profile</p> 
<p>Effects of increased stick-out</p> <ul style="list-style-type: none"> Higher deposition rate Less penetration Higher bead Lower arc voltage 	<p>Effects on weld profile</p> 
<p>Effects of increased wire diameter</p> <ul style="list-style-type: none"> Possibility of increased deposition rate Less penetration Wider bead 	<p>Effects on weld profile</p> 

Effects of type of current and polarity	Effects on weld profile
DC+ Deepest penetration Highest dilution Lowest deposition rate	
AC Lower penetration Lower dilution Higher deposition rate than DC+	
DC- Higher deposition rate than AC Lowest dilution Lowest penetration Mainly used for cladding	
	Max. penetration Slow travel speed Less penetration Higher travel speed Least penetration Highest travel speed

Effects of electrode angle in butt welds

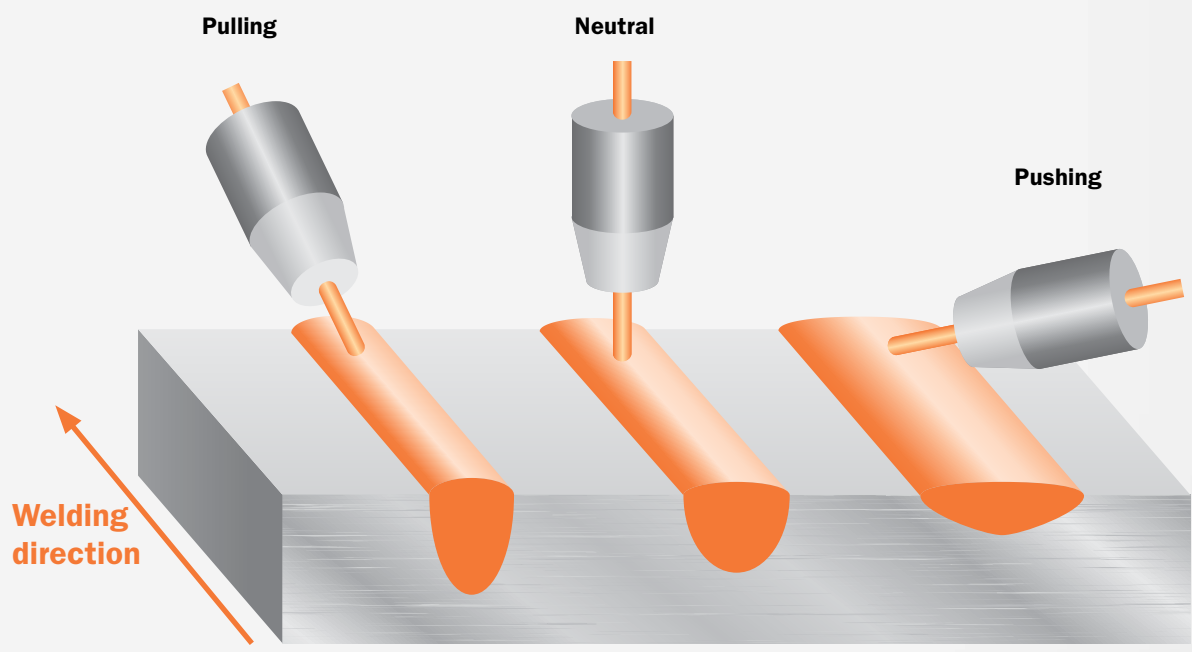

Penetration:	Deep	Moderate	Shallow
Reinforcement:	Maximum	Moderate	Minimum
Risk of hot cracking:	High	Low	Low

Submerged Arc Welding Process

Circumferential welds

Here are some guidelines to follow when making Submerged Arc Welds on circumferential weldments:

- For outside diameter welds, position the wire/weld pool ahead of the point to where the weld pool will travel uphill to the vertical center line of the weldment. For example, if making a weld on a pipe, the puddle would be at the 11 o'clock position for a clockwise rotation and the weld pool would be traveling to the 12 o'clock position as it solidifies (*Figure 1*). For outside diameter welds, angle the electrode toward the direction of travel. The amount of displacement from the center line (12 o'clock position) will vary with each cylinder diameter (*Table 1*).
- For inside diameter welds position the wire/weld pool ahead of the point to where the weld pool will travel downhill to the vertical center line of the weldment. For example, if making a weld on the inside of a pipe, the puddle would be at the 5 o'clock position for a clockwise rotation and the weld pool would be traveling to the 6 o'clock position as it solidifies (*Figure 1*). For inside diameter welds, angle the electrode away from the direction of travel. The amount of displacement from the center line (6 o'clock position) will vary with each cylinder diameter (*Table 1*).
- Limit bead sizes by reducing the amperage (wire feed speed), reducing the voltage, using smaller diameter wire or using faster travel speeds. Small beads solidify faster and the fused flux cools quicker for easier slag removal.
- Support the flux with flux dams or shields to maintain proper flux depth at the arc.
- Consult Hobart for information on fast-freezing wire and flux combinations.
- Small multiple passes in heavy metals reduce the possibility of undercutting and give better contour for easier slag removal.

Cylinder diameter	Wire displacement
2.5–7.6 cm (1–3")	10–19 mm (0.375–0.75")
7.6–46 cm (3–18")	19–25 mm (0.75–1")
46–91 cm (18–36")	32–38 mm (1.25–1.5")
91–107 cm (36–42")	38–44 mm (1.5–1.75")
107–122 cm (42–48")	44–50 mm (1.75–2")
122–183 cm (48–72")	50–64 mm (2–2.5")
183 cm+ (72"+)	76 mm (3")

Table 1 — Displacement from the 12 or 6 o'clock center line for circumferential welds.

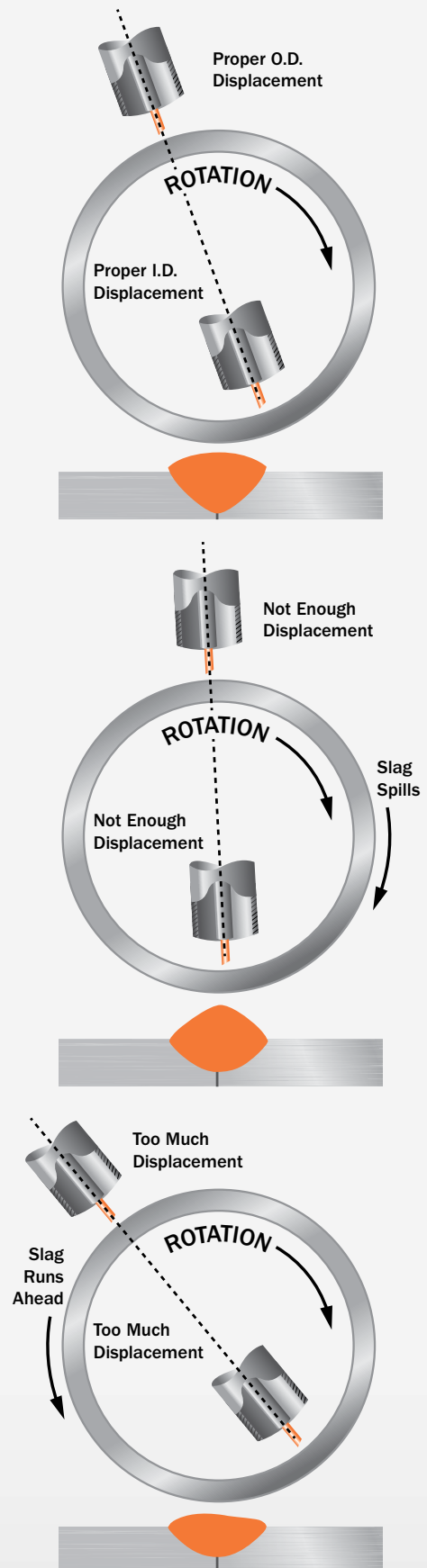

Figure 1 — Torch placement for circumferential SAW.

Fillet welds

Fillet welds generally use lower voltages than groove welds at the same amperages (wire feed speed). Using a single wire, a 10-mm (3/8") fillet weld can be deposited in one pass/run. Larger single-pass, horizontal fillet beads can be made with multiple wires. Fillet welds 8 mm (5/16") and larger are made in the flat position by repositioning the work. Submerged Arc welding will generally produce fillet welds with deeper penetration than welds of the same size made using other arc welding processes.

The bead width-to-depth ratio should be carefully regulated. The bead width should be 20–25 percent greater than the depth to prevent cracking. Even when welding procedures are rigidly followed, fillet welds may crack due to the highly restrained nature of fillet welds. Complete joint penetration in a fillet weld will occur when the weld deposit is at the point aligned with the wire's axis. This can be accomplished by angling the torch or tilting the workpiece to obtain the correct joint angle (*Figure 2*).

Special precautions should be taken to prevent arc blow problems in fillet welds. Intersecting workpieces can intensify arc blow problems which may produce porosity and an uncontrollable weld bead.

Lap welds

Good fit-up and proper electrode alignment are prime considerations for good lap welds. If plates aren't tightly held together, the gaps will produce poor bead shape and potentially defective welds. A clean plate, free from all contaminants, is particularly important to good lap weld quality. If the wire is improperly positioned incomplete joint penetration or burn-through will occur (*Figure 3*).

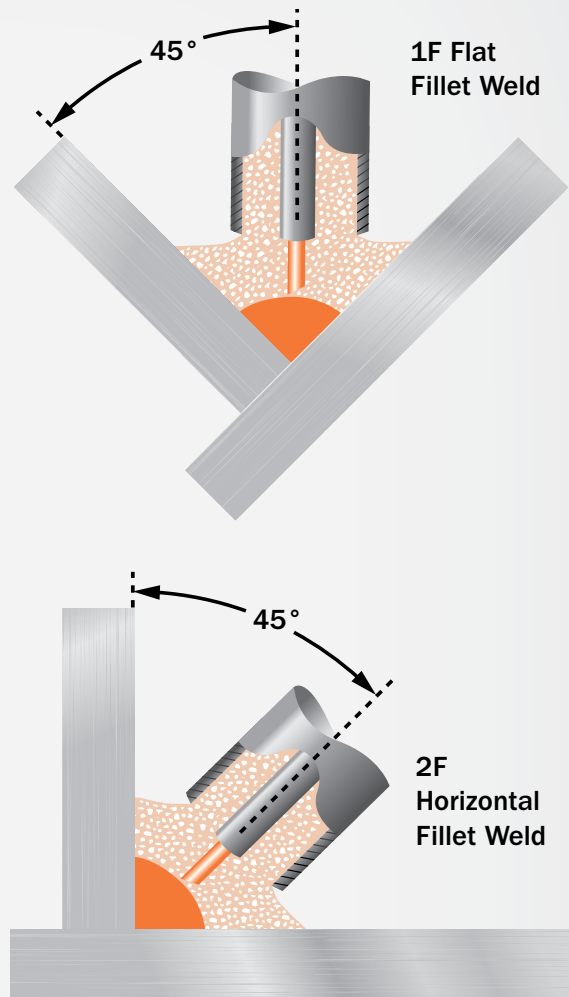

Figure 2 — Torch placement for SAW fillet welds on T-joints.

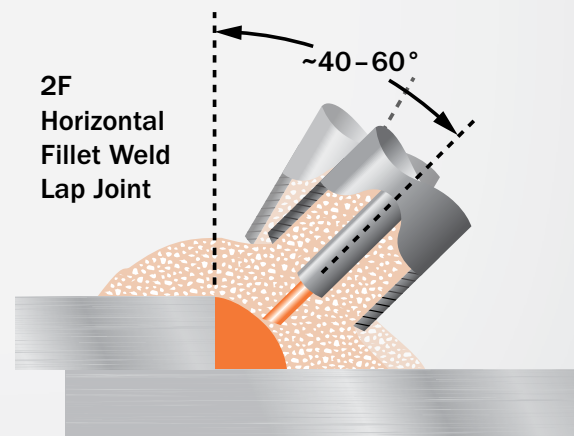
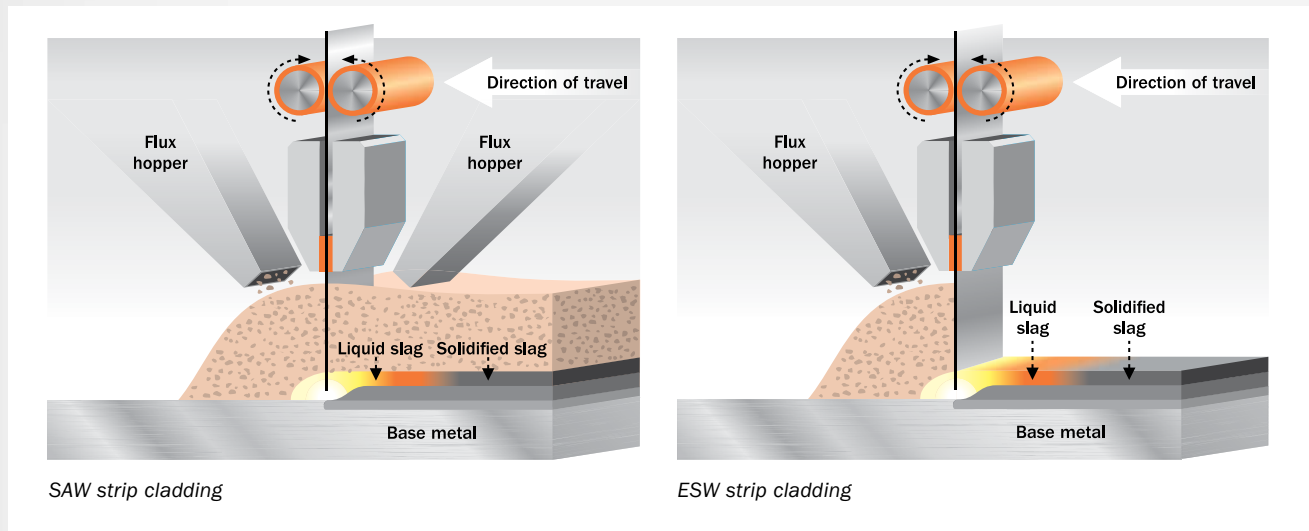

Figure 3 — Torch placement for SAW fillet welds on lap joints.

SAW and ESW Strip Cladding

Strip cladding is used to create corrosion or wear-resistant overlays on large non- or low-alloyed steel components used in, for example, the chemical, petrochemical, nuclear, steel mills and paper and pulp industries. It provides a cost-efficient solution over using components in full stainless steel or Ni-alloys.



Two process technologies

One technology is Submerged Arc strip cladding, formally denominated SASC, but normally referred to as SAW strip cladding. The other method is Electroslag strip cladding. The formal designation is ESSC, but is mostly called ESW strip cladding.

The SAW and ESW strip cladding processes use a strip electrode to cover a wide area with each run. Strip dimensions are typically 30, 60 or 90 x 0.5 mm, but there is an increasing interest in 120 mm wide strip. Specially developed welding fluxes are needed to obtain the right characteristics for each process.

SAW strip cladding is an arc welding process. The function of the flux is basically the same as in standard Submerged Arc welding. It forms a slag to protect the weld pool and supports the formation of the weld bead.

In ESW strip cladding there is no arc between the strip and the parent metal and the flux is fed from only one side. The molten slag is electrically conductive and the heat needed to melt the strip and the parent metal surface is generated by the electrical resistance in the weld pool. Because of this, penetration and thus dilution is lower than with SAW cladding. Due to the high temperature of the weld pool and the high welding current a heavy-duty welding head is necessary. The high welding current may cause weld defects such as uneven weld bead. This can be prevented by using a magnetic steering device for larger strip widths (≥ 60 mm/2.4"). Moreover the ESW strip cladding process burns off some elements from the strip at a higher rate than SAW. The implication is that the strip for ESW cladding has to have a slightly different chemistry than SAW to achieve the desired chemistry of the deposit.

Comparison between the SAW and ESW cladding methods

Strip 60 x 0.5 mm	SAW	ESW
Deposition rate	12–15 kg/h (26–33 lbs/h)	20–27 kg/h (44–59 lbs/h)
Travel speed	10–12 cm/min (4–5 inch/min)	18–24 cm/min (7–10 inch/min)
Arc voltage	26–28 V	24–26 V
Current	700–800 A	1200–1450 A
Dilution	~20%	~10%
Penetration	>0.8 mm (>0.03")	<0.5 mm (<0.02")
Heat input	~12 kJ/mm	~12 kJ/mm
No. of layers	Min 2	Min 1
Deposit thickness	~8.5 mm (~1/3")	~4.5 mm (~3/16")
Flux consumption	0.8 kg/kg strip (0.8 lbs/lbs strip)	0.6 kg/kg strip (0.6 lbs/lbs strip)

ESW strip cladding has the following benefits over SAW strip cladding:

- Increased deposition rate
- High travel speed
- Low dilution
- Less penetration
- Comparable heat input
- Lower flux consumption
- Weld deposit obtainable in one layer

For both SAW and ESW strip cladding, standard SAW DC power sources are used. However, the current capacity has to be more or less doubled for ESW strip cladding, meaning that the investment cost for power sources will be at least doubled compared to SAW strip cladding. Furthermore ESW requires water cooling and in many cases magnetic steering devices increasing the difference in investment costs further. However, when ESW strip cladding is technically feasible in the application, the incremental investment costs for ESW compared to SAW are typically easily offset by the increased deposition rate and the fact that it is possible to reach the desired weld metal chemistry in one layer.

The current Hobart flux program features one flux for SAW strip cladding and three fluxes for ESW strip cladding.

SWX 305

SAW strip cladding with austenitic stainless steel strip

SWX 330

ESW strip cladding with austenitic stainless steel strip

SWX 340

ESW high-speed strip cladding with austenitic stainless steel strip

SWX 382

ESW cladding with Ni-base strip

Deposition rate SAW/ESW strip cladding

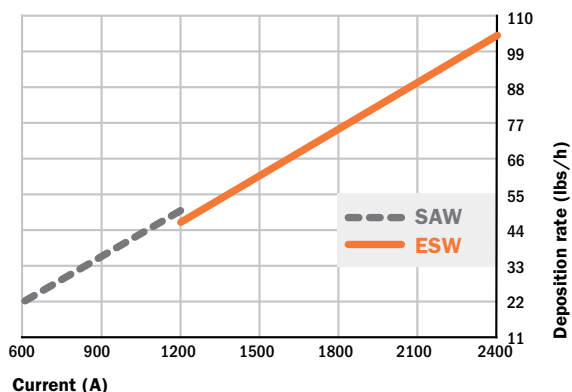

As ITW Welding companies, Miller and Hobart are a total solution provider. An overview of our offerings for Submerged Arc welding, Submerged Arc strip cladding and Electroslag strip cladding is presented in the back of this catalog.

Submerged Arc Power Sources and AC Wave Balance

The performance of power sources is essential in mechanized or fully automated Submerged Arc welding, where they are often subjected to high duty cycles at high welding currents. A power source needs to be able to operate at welding currents as low as 300 A for thin materials and over 1000 A for thick materials, at up to 100% duty cycle. Robustness and durability are primary requirements, along with advanced electronic Submerged Arc functionality giving full control over the arc and its effects on the weld.

Power source characteristics

Constant current (CC) and constant voltage (CV) are two important principles. They used to be applied in separate Submerged Arc power source types, but are nowadays available in a single machine and can be switched on and off when needed.

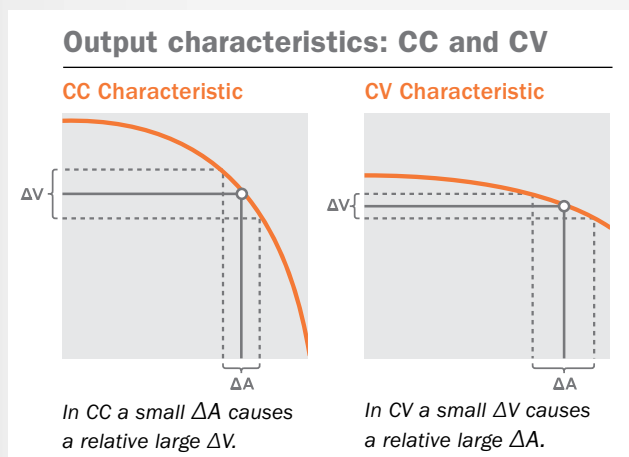

A CC characteristic shows a relatively steep downward slope in the volt/ampere curve. The welding current is the primary parameter set on the machine. Fluctuations in arc length/arc voltage (ΔV) — which are inevitable during welding — will only cause small variations in amperage (ΔA). To obtain a stable process, arc voltage sensing wire feeders constantly adapt the wire feed speed to maintain

the welding current at the set value. CC is best applicable with larger diameter wires fed at comparatively low wire feed speeds, because this places lower demands on the wire feed speed range and acceleration of the motors. However, with today's (tacho-controlled) wire feed motors, CC can be applied with smaller diameter wires as well. The constant current provides stable and dependable weld penetration when welding materials with medium or high wall thickness.

A CV characteristic allows the use of thin welding wires while maintaining a stable arc. The volt/ampere curve is relatively flat. The arc voltage is the primary parameter set on the power source. Small fluctuations in arc voltage (ΔV) will cause relatively big changes in amperage (ΔA), while the wire feed speed remains the same. A higher voltage gives lower amperage and consequently a lower melt-off rate of the wire. A lower voltage gives higher amperage and accelerated wire melt-off. In this self-regulating way, the process balances around the set voltage/arc length.

CV can be applied with all wire diameters, but performs best below 2.4 mm (3/32") diameter, due to the self-regulating effect. It is best suited for welding thin materials up to 12 mm (1/2") and for strip cladding. The constant voltage gives straight welds with constant bead width.

Making use of polarity

As listed under "Effects of welding parameters" (pages 60–61) polarity has an effect on penetration, deposition, dilution, heat input and arc stability. Use of this is being made in different SAW processes and process variants.

DC+ gives the deepest weld penetration and highest parent metal dilution, because most heat is developed at the surface of the weld pool.

This table summarizes the most important features of CC and CV applied in Submerged Arc power sources.

Feature	CC	CV
Open circuit voltage	60–80 V	25–55 V
Parameter setting	By welding current	By arc voltage
Polarity	AC / DC	AC / DC
Arc stability	Fluctuations	Stable
Arc regulation	Through wire feed speed	Self-regulating
Application (best practice)	Larger diameter wires	Smaller and larger diameter wires

It also gives a stable arc, an optimal weld appearance, a good weld profile and reduced risk of porosity. For these reasons, DC+ is commonly used for single- and twin-wire welding and for the leading wire in tandem and multi-wire operations.

Traditional sinusoidal AC gives ~15% higher deposition rate than DC+, shallower weld penetration and lower dilution. It is commonly used for trailing wires in tandem and multi-wire systems to counteract magnetic arc blow and provides increased deposition. A drawback of conventional sinusoidal wave AC is poor arc ignition and stability, because the current passes through the zero point with a certain delay, due to the wave form. This disadvantage is taken away by modern AC squarewave power sources.

DC- gives the highest deposition rate (~35% higher than DC+), because most heat is developed at the tip of the wire electrode. The main applications, however, make use of the reduced penetration and lower weld metal dilution. Examples are difficult-to-weld materials and strip cladding, where dilution with the parent metal needs to be limited.

Modern AC squarewave power sources provide interesting possibilities to vary the DC+/DC- ratio and their frequencies in AC welding, giving full control over deposition rate and penetration.

AC squarewave technology

AC squarewave technology applied in welding offers useful opportunities to shape the form of the AC sinus and influence essential welding characteristics such as penetration, deposition rate and travel speed, without changing the volt/ampere setting. It was one in a series of power source innovations to bring Submerged Arc welding to a higher performance level:

- AC squarewave replacing sinusoidal AC
- AC/DC with CC and CV replacing AC with CC characteristic only
- Variable AC frequency
- Variable balance of electrode positive and negative instead of fixed 50/50

Squarewave technology in welding power sources is based on either inverter or thyristor technology to control the wave form. Both technologies allow changing the AC+/AC- ratio (= AC wave balance).

Effects of wave balance

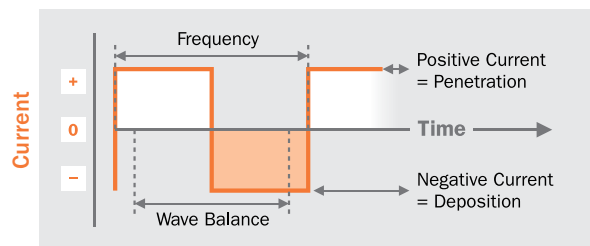

Wave balance = adjustable ratio between penetration/deposition.

Why apply AC squarewave

Both DC+ and conventional sinusoidal AC are widely applied in Submerged Arc welding systems, offering weld quality and productivity in any type of fabrication. The use of AC wave balance must be seen as a next step in the optimization of Submerged Arc welding, overcoming specific constraints while opening up new possibilities.

Constraints of conventional sinusoidal AC are:

- Time spent in the zero crossover area affects arc starts and arc stability negatively
- Lower percentage of time spent at set amperage lowers productivity
- AC+/AC- ratio is fixed at 50/50

Constraints of traditional DC+ are:

- Penetration can be too deep for the root pass causing burn through
- Low heat input and high deposition not obtainable at the same time without sacrificing bead appearance
- Sensitive to magnetic arc blow

Submerged Arc Power Sources and AC Wave Balance

AC squarewave technology has two main advantageous properties — the AC wave block form and the variable AC wave balance. Due to the block form, the current passes through the crossover area in milliseconds resulting in good arc starts and stability and more dwell time at set current.

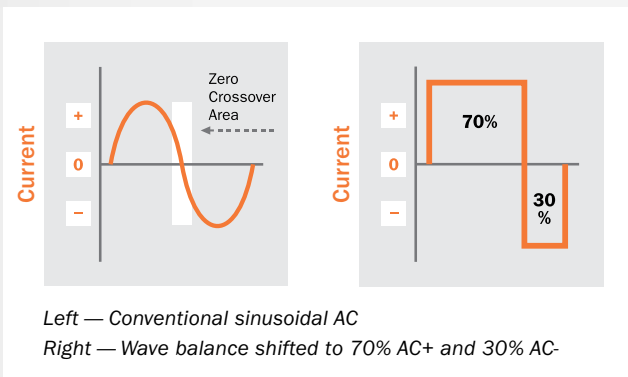

The variable AC wave balance makes it possible to alter the share of AC+ versus AC- to any desired ratio and thereby to influence penetration and deposition rate. Increasing the + share will give deeper penetration and reduced deposition, while increasing the minus share will do the opposite.

Test data

The following table reviews results of test welds with a variety of balance settings. Deposition rate and wire feed speed were measured for each setting. Welding parameters remained the same for all balance settings.

Balance setting	Actual wfs		Deposition	
	(m/min)	(inches/min)	(kg/h)	(lbs/h)
DC+	2.1	83	7.9	17.4
80/20	2.3	90	8.7	19.2
70/30	2.5	98	9.4	20.7
76/33	2.6	102	9.8	21.6
60/40	2.7	106	10.2	22.5
50/50	2.8	110	10.5	23.1
40/60	2.9	114	10.9	24.0
33/67	3.0	118	11.3	24.9
30/70	3.1	122	11.5	25.3
20/80	3.1	122	11.7	25.8
DC-	3.2	126	12.0	26.5

Solid wire 3.2 mm (1/8"), 600 A, 31 V,
50 cm/min (20"/min), 30 mm (1.2") ESO

Effect on penetration

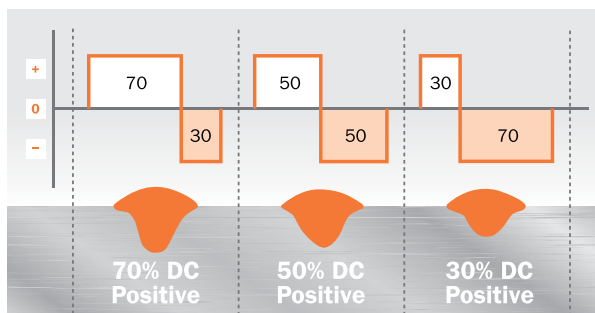

Effect on travel

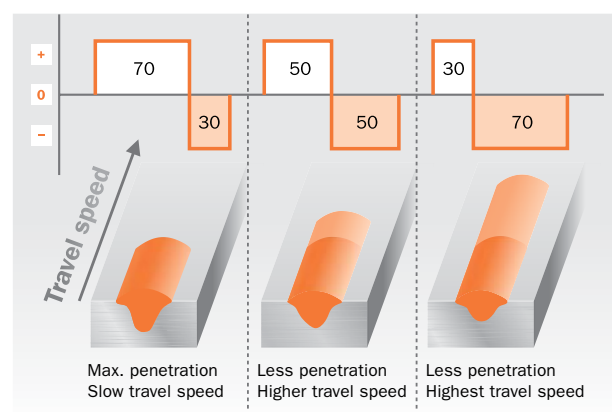

The images above show the effects of AC wave balance on penetration and on the adapted travel speed needed to accommodate increased deposition. Note that an increase in travel speed with other parameters remaining the same will result in a lower heat input and reduced plate deformation.

AC wave balance options summarized

AC wave balance offers the following options in single- and multi-wire Submerged Arc welding:

- Fine tuning of root penetration and deposition rate from single or lead wires
- Increase of deposition rate from trailing wires
- Increase of travel speed and reduction of heat input
- Reduction of deformation
- Elimination of arc blow

Miller AC wave balance

The SubArc AC/DC 1000/1250 Digital is Miller's latest AC power source with variable squarewave balance (VBAC) for Submerged Arc welding. It is based on the proven SCR phase shift technology which Miller implemented in welding equipment as early as 1999 — years ahead of the first inverter squarewave power source.

SubArc AC/DC 1000/1250 Digital features:

- Reliability. Like all Miller welding machines it is built for operations under heavy conditions, with low maintenance and long lifetime. Only one PC board is used for the entire machine.
- DC or VBAC + CC/CV characteristics, three-phase primary. 1000 A at 100% duty cycle, 1250 A at 60% duty cycle.
- A preset choice of 14 wave balance/frequency settings — easy to use, tested to industry-best standards covering the majority of applications. This avoids complicated setting and testing with freely adjustable wave balance parameters.
- No special equipment needed to connect power sources for multi-arc operation.

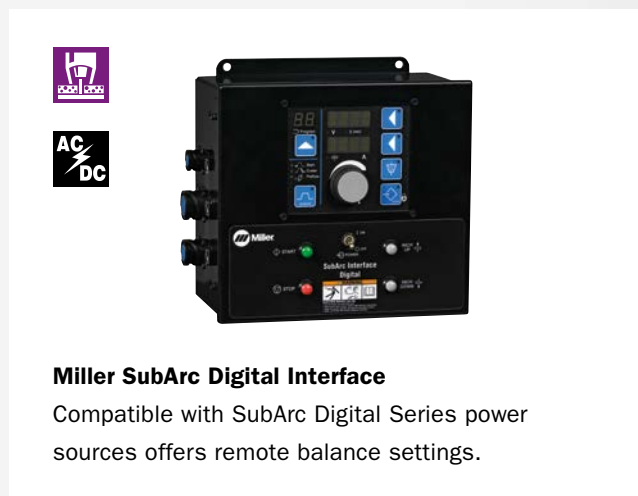

Miller SubArc Digital Interface



Compatible with SubArc Digital Series power sources offers remote balance settings.

Standard wave balance/frequency settings

available from the SubArc Digital Interface.

Balance	Frequency	
	60 Hz line (US)	50 Hz line
Electrode positive	--	--
80/20	18	15
75/25	23	19
70/30	18	15
67/33	30	25
60/40	18	15
50/50	30	25
50/50	18	15
40/60	18	15
33/67	30	25
30/70	18	15
25/75	23	19
20/80	18	15
Electrode negative	--	--

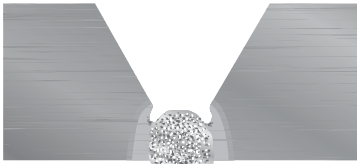
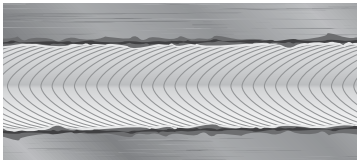
Troubleshooting

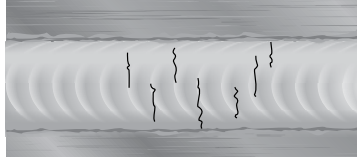
<p>Porosity</p> 	<p>Probable cause</p> <ul style="list-style-type: none"> Rusty plate Oily plate Wet plate Wet flux Primer in welding zone Flux layer too thin Contaminated joint Arc blow 	<p>Solution</p> <ul style="list-style-type: none"> Wire brush or grind Degrease or preheat Preheat Re-dry flux Remove primer Increase flux bed height Clean joint Reposition ground
<p>Undercut</p> 	<p>Probable cause</p> <ul style="list-style-type: none"> Voltage too high Travel speed too high 	<p>Solution</p> <ul style="list-style-type: none"> Adjust parameters Adjust travel speed
<p>Tight slag</p> 	<p>Probable cause</p> <ul style="list-style-type: none"> Voltage too high Incorrect wire size Irregular weld Welding zone too hot Joint prep too narrow 	<p>Solution</p> <ul style="list-style-type: none"> Adjust parameters Adjust parameters Adjust parameters Cool down Adapt joint design
<p>Burn-through</p> 	<p>Probable cause</p> <ul style="list-style-type: none"> Current too high Voltage too low Travel speed too low Root face too small Poor fit-up 	<p>Solution</p> <ul style="list-style-type: none"> Adjust parameters Adjust parameters Adjust parameters Adjust parameters Improve fit-up
<p>Longitudinal cracks</p> 	<p>Probable cause</p> <ul style="list-style-type: none"> Concave bead profile Weld depth/width ratio > 1 Poor fit-up Rigid construction Excessive length of weld pool 	<p>Solution</p> <ul style="list-style-type: none"> Adjust parameters and torch position Adjust parameters Improve fit-up Preheat Adjust parameters
<p>Transverse cracks</p> 	<p>Probable cause</p> <ul style="list-style-type: none"> Cooling rate too high Excessive restraint Moisture in flux 	<p>Solution</p> <ul style="list-style-type: none"> Preheat, increase interpass temperature, use preheated flux Preheat or adapt design Re-dry flux

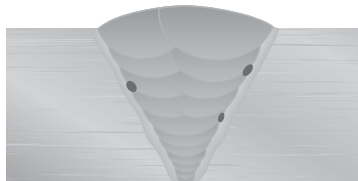
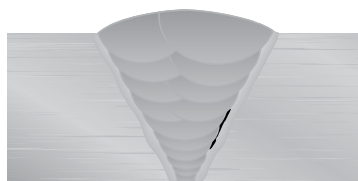
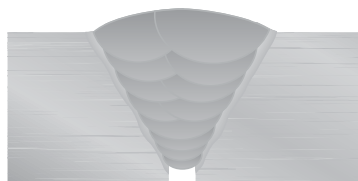
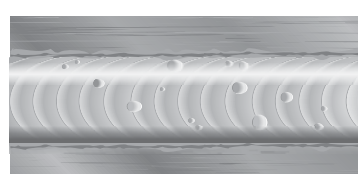
Poor weld appearance	Probable cause	Solution
	Travel speed too high	Adjust parameters
	Voltage too low	Adjust parameters
	Current too high	Adjust parameters
	Poor fit-up	Improve fit-up
Slag inclusions	Probable cause	Solution
	Flux trapped in joint	Adjust torch angle and parameters. Change joint angle/design
	Joint opening angle too small	Adapt joint design
	Insufficient penetration	Adjust parameters
Cold lap	Probable cause	Solution
	Plate temperature too low	Preheat
	Heat input too low	Adjust parameters
	Travel speed too high	Adjust parameters
	Negative polarity	Adjust parameters
Lack of penetration	Probable cause	Solution
	Current too low	Adjust parameters
	Travel speed too high	Adjust parameters
	Root face too large	Adapt joint design
Pock marks	Probable cause	Solution
	Excessive flux bed depth	Reduce flux bed depth
	Dirty wire	Use new wire
	Dirty plate	Clean plate or change flux/wire combination
	Moisture	Preheat plate
	Wrong flux/wire combination	Change to higher deoxidizing wire and more active flux

Packaging and Pallet Information

27 kg (60 lb) coil

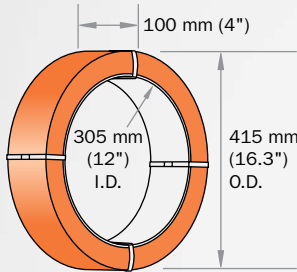

Weight: 27 kg (60 lbs)

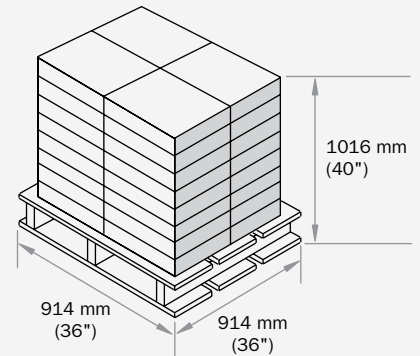
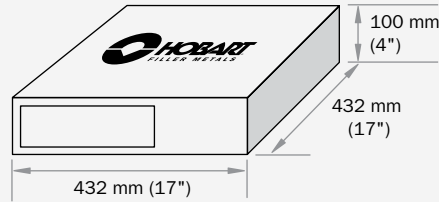

Items per pallet: 32

Pallet net weight: 871 kg (1920 lbs)

25 kg (55 lb) spool — wire basket K-415

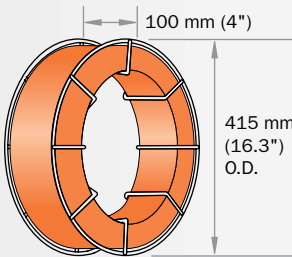

Weight: 25 kg (55 lbs)

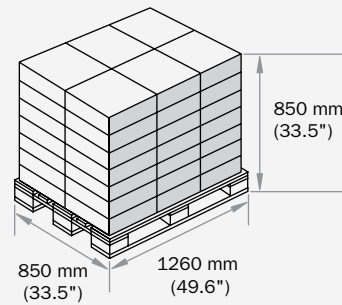
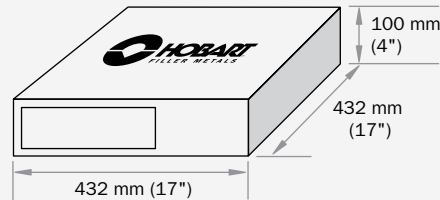
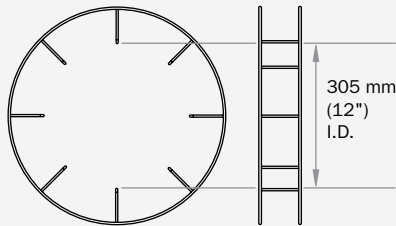

Items per pallet: 42

Pallet net weight: 1050 kg (2310 lbs)

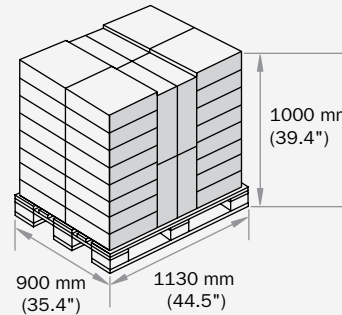

Items per pallet: 40

Pallet net weight: 1000 kg (2200 lbs)

100 kg (220 lb) spool — wire basket K-570

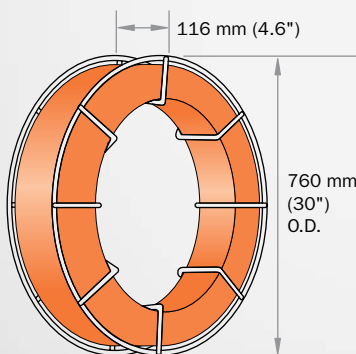

Weight: 100 kg (220 lbs)

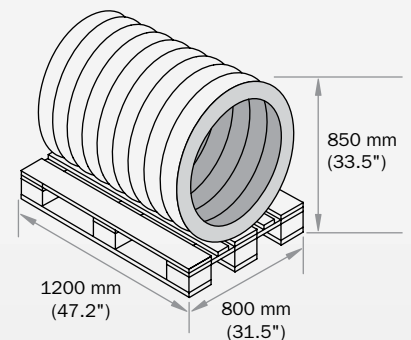
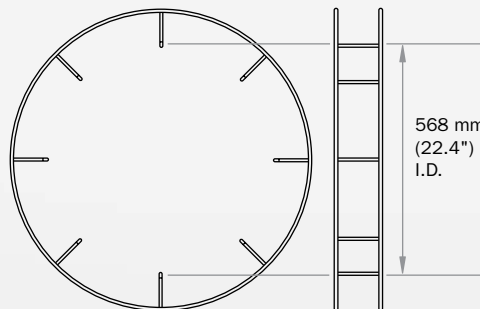

Items per pallet: 9

Pallet net weight: 900 kg (1980 lbs)

Note: These are our standard package types. Other types may be available on request.

Pay-off drums

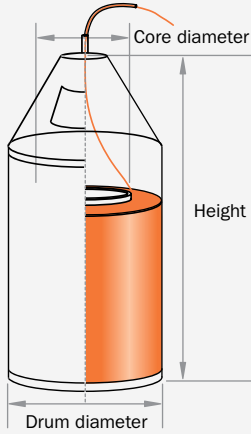

Drum weight	Drum diameter	Core diameter	Drum height	Items per pallet	Pallet net weight	Pallet width	Pallet depth	Overall height
272 kg (600 lbs)	585 mm (23")	410 mm (16")	890 mm (35")	2	545 kg (1200 lbs)	660 mm (26")	1220 mm (48")	910 mm (35.8")
300 kg (660 lbs)	580 mm (22.8")	430 mm (17")	940 mm (37")	4	1200 kg (2640 lbs)	1150 mm (45.3")	1150 mm (45.3")	1060 mm (41.7")
454 kg (1000 lbs)	650 mm (25.6")	450 mm (17.7")	950 mm (37.4")	2	910 kg (2000 lbs)	700 mm (27.6")	1320 mm (52")	1070 mm (42.1")

Note: Standard pay-off direction is clockwise. Requires a turntable.

Large coils

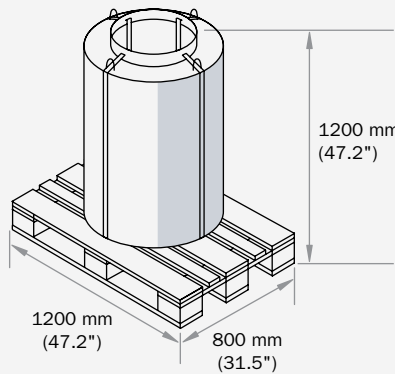
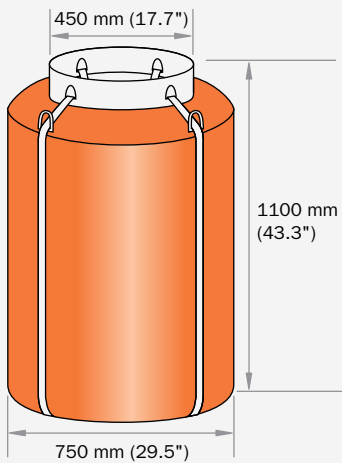

Weight: 1000 kg (2200 lbs)
 Items per pallet: 1
 Pallet net weight: 1000 kg (2200 lbs)
 Note: Standard pay-off direction is clockwise. Requires a turntable.

EAE (aluminium foil) flux bags

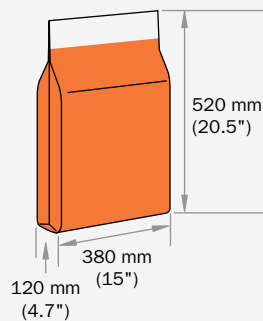

Weight:
 22.7 kg / 25 kg
 (50 lbs / 55 lbs)

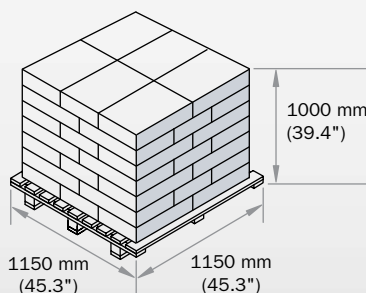

Items per pallet: 42
 Pallet net weight:
 953 kg / 1050 kg
 (2100 lbs / 2310 lbs)

DoubleBag™ (aluminium-lined) flux bags

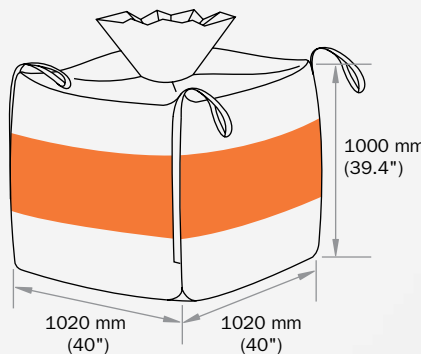

Weight:
 950 kg / 1000 kg
 (2090 lbs / 2200 lbs)

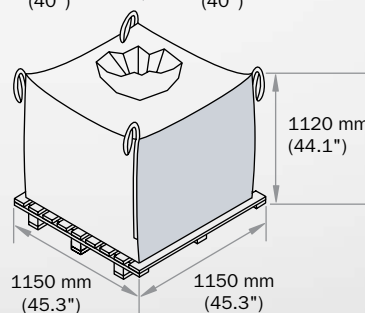

Items per pallet: 1
 Pallet net weight:
 950 kg / 1000 kg
 (2090 lbs / 2200 lbs)

Conversion Charts

Toughness

Formulas

ft-lbs	J
1	1.356
0.738	1

ft-lbs	J
15	20
22	30
27	37
30	40
35	47
37	50
44	60
52	70
59	80
66	90
74	100
89	120
103	140
118	160
133	180
148	200
162	220
177	240
192	260
207	280
221	300

Conversion J – ft-lbs

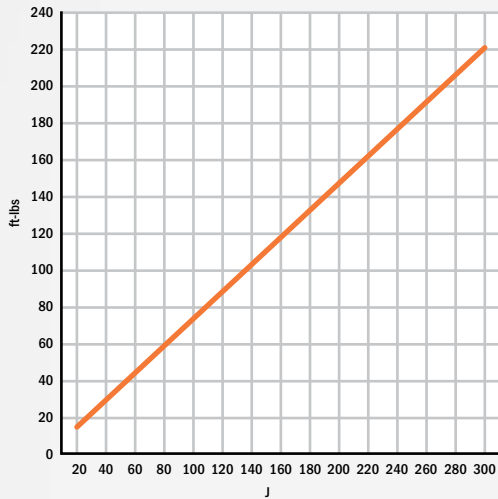

Strength

Formulas

ksi	MPa
1	6.895
0.145	1

ksi	MPa
44	300
51	355
58	400
61	420
65	448
67	460
70	483
73	500
75	517
80	552
85	586
90	620
100	690
110	758
115	790
120	827
129	890
145	1000
160	1100

Conversion MPa – ksi

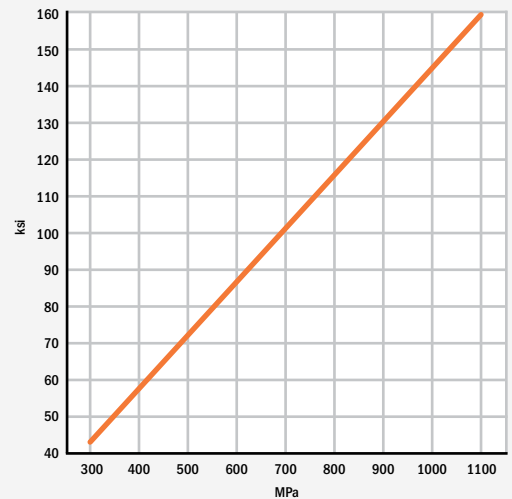

Temperature (Low)

Formulas

$^{\circ}\text{F} = ^{\circ}\text{C} * 9/5 + 32$
$^{\circ}\text{C} = (^{\circ}\text{F} - 32) * 5/9$

$^{\circ}\text{F}$	$^{\circ}\text{C}$
-321	-196
-148	-100
-120	-84
-112	-80
-100	-73
-80	-62
-76	-60
-60	-51
-58	-50
-50	-46
-40	-40
-20	-29
-4	-20
0	-18
32	0
50	10
68	20

Conversion $^{\circ}\text{C} - ^{\circ}\text{F}$

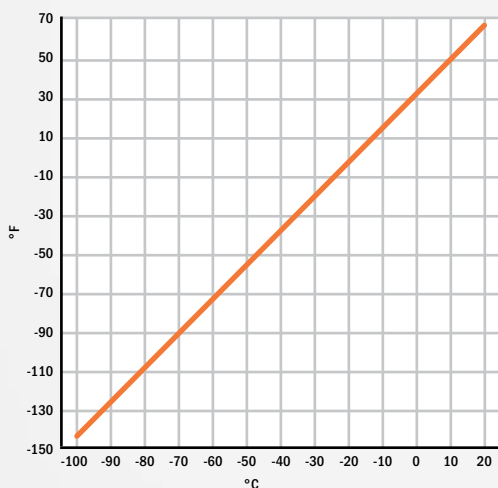

Temperature (High)

Formulas

$^{\circ}\text{F} = ^{\circ}\text{C} * 9/5 + 32$
$^{\circ}\text{C} = (^{\circ}\text{F} - 32) * 5/9$

$^{\circ}\text{F}$	$^{\circ}\text{C}$
572	300
662	350
700	371
752	400
800	427
842	450
900	482
932	500
1000	538
1022	550
1100	593
1112	600
1150	621
1202	650
1250	677
1292	700
1382	750

Conversion $^{\circ}\text{C} - ^{\circ}\text{F}$

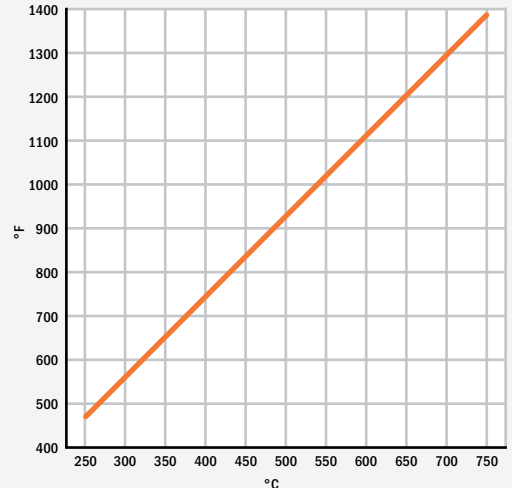

EN ISO 14174: Fluxes for Submerged Arc welding

Example:



S — Flux for Submerged Arc welding

ES — Flux for Electroslag welding

Flux type	
F	Fused flux
A	Agglomerated flux
M	Mixed flux

Flux type	
Symbol	Flux type (extract)
MS	Manganese-silicate
CS	Calcium-silicate
ZS	Zirconium-silicate
RS	Rutile-silicate
AR	Aluminate-rutile
AB	Aluminate-basic
AS	Aluminate-silicate
AF	Aluminate-fluoride-basic
FB	Fluoride-basic
Z	Any other composition

Application	
Class	
1	Non- and low-alloyed steels
2	Stainless and nickel-base alloys
2b	Fluxes especially designed for strip cladding
3	Hard facing (overlay welding) with alloy transfer from flux
4	Other fluxes not classified as 1, 2, 2b, or 3

Hydrogen content	
Symbol	ml/100g deposited weld metal
H5	<5
H10	<10
H15	<15

Type of current	
Symbol	
DC	DC only
AC	AC or DC

Class 1 fluxes — Metallurgical behavior (weight %)		
Symbol	Behavior	Contribution from flux
1	Burn-off	0.7–
2	Burn-off	0.5–0.7
3	Burn-off	0.3–0.5
4	Burn-off	0.1–0.3
5	Neutral	0–0.1
6	Pick-up	0.1–0.3
7	Pick-up	0.3–0.5
8	Pick-up	0.5–0.7
9	Pick-up	0.7–

Si and Mn alloying. First symbol is for Si and the second symbol is for Mn alloying.

Class 2 and 2b fluxes — Metallurgical behavior (weight %)						
Symbol	Behavior	C	Si	Cr	Nb	
1	Burn-off	> 0.020	> 0.7	> 2.0	> 0.20	
2	Burn-off	-	0.5–0.7	1.5–2.0	0.15–0.20	
3	Burn-off	0.010–0.020	0.3–0.5	1.0–1.5	0.05–0.15	
4	Burn-off	-	0.1–0.3	0.5–1.0	0.05–0.10	
5	Neutral	0.000–0.010	0.0–0.1	0.0–0.5	0.00–0.05	
6	Pick-up	-	0.1–0.3	0.5–1.0	0.05–0.10	
7	Pick-up	0.010–0.020	0.3–0.5	1.0–1.5	0.10–0.15	
8	Pick-up	-	0.5–0.7	1.5–2.0	0.15–0.20	
9	Pick-up	>0.020	>0.7	>2.0	> 0.20	

Solid line: Classification requirement
Dotted line: Optional classification

EN ISO 14171-A: Solid wires, cored wires and wire/flux combinations for Submerged Arc welding of non-alloyed and fine grain steels

Solid wire example:

SWX 110 / SDX S2Si-EM12K

S 38 4 AB S2Si

S — Flux for Submerged Arc welding

Tensile properties			
Symbol	Rel/Rp0.2 min. (MPa)	Rm (MPa)	A min. (%)
35	355	440–570	22
38	380	470–600	20
42	420	500–640	20
46	460	530–680	20
50	500	560–720	18

Impact properties

Symbol	Min. 47J at °C
Z	
A	+20
0	0
2	-20
3	-30
4	-40
5	-50
6	-60
7	-70
8	-80
9	-90
10	-100

Flux type according to EN ISO 14174

Symbol	Flux type (extract)
MS	Manganese-silicate
CS	Calcium-silicate
ZS	Zirconium-silicate
RS	Rutile-silicate
AR	Aluminate-rutile
AB	Aluminate-basic
AS	Aluminate-silicate
AF	Aluminate-fluoride-basic
FB	Fluoride-basic
Z	Any other composition

EN ISO 14171 — Chemical composition solid wire (%)

Symbol	C	Si	Mn	Mo	Ni	Cr	Cu*
S1	0.05–0.15	0.15	0.35–0.60	0.15	0.15	0.15	0.30
S2	0.07–0.15	0.15	0.80–1.30	0.15	0.15	0.15	0.30
S3	0.07–0.15	0.15	1.30–1.75	0.15	0.15	0.15	0.30
S4	0.07–0.15	0.15	1.75–2.25	0.15	0.15	0.15	0.30
S1Si	0.07–0.15	0.15–0.40	0.35–0.60	0.15	0.15	0.15	0.30
S2Si	0.07–0.15	0.15–0.40	0.80–1.30	0.15	0.15	0.15	0.30
S2Si2	0.07–0.15	0.40–0.60	0.80–1.30	0.15	0.15	0.15	0.30
S3Si	0.07–0.15	0.15–0.40	1.30–1.85	0.15	0.15	0.15	0.30
S4Si	0.07–0.15	0.15–0.40	1.85–2.25	0.15	0.15	0.15	0.30
S1Mo	0.05–0.15	0.05–0.25	0.35–0.60	0.45–0.65	0.15	0.15	0.30
S2Mo	0.07–0.15	0.05–0.25	0.80–1.30	0.45–0.65	0.15	0.15	0.30
S2MoTiB**	0.05–0.15	0.15–0.35	1.00–1.35	0.40–0.65			0.30
S3Mo	0.07–0.15	0.05–0.25	1.30–1.75	0.45–0.65	0.15	0.15	0.30
S4Mo	0.07–0.15	0.05–0.25	1.75–2.25	0.45–0.65	0.15	0.15	0.30
S2Ni1	0.07–0.15	0.05–0.25	0.80–1.30	0.15	0.80–1.20	0.15	0.30
S2Ni1.5	0.07–0.15	0.05–0.25	0.80–1.30	0.15	1.20–1.80	0.15	0.30
S2Ni2	0.07–0.15	0.05–0.25	0.80–1.30	0.15	1.80–2.40	0.15	0.30
S2Ni3	0.07–0.15	0.05–0.25	0.80–1.30	0.15	2.80–3.70	0.15	0.30
S2Ni1Mo	0.07–0.15	0.05–0.25	0.80–1.30	0.45–0.65	0.80–1.20	0.20	0.30
S3Ni1.5	0.07–0.15	0.05–0.25	1.30–1.70	0.15	1.20–1.80	0.20	0.30
S3Ni1Mo	0.07–0.15	0.05–0.25	1.30–1.80	0.45–0.65	0.80–1.20	0.20	0.30
S3Ni1Mo0.2	0.07–0.15	0.10–0.35	1.20–1.60	0.15–0.30	0.80–1.20	0.15	0.30
S3Ni1.5Mo	0.07–0.15	0.05–0.25	1.20–1.80	0.30–0.50	1.20–1.80	0.20	0.30
S2Ni1Cu	0.06–0.12	0.15–0.35	0.70–1.20	0.15	0.65–0.90	0.40	0.40–0.65
S3Ni1Cu	0.05–0.15	0.15–0.40	1.20–1.70	0.15	0.60–1.20	0.15	0.30–0.60
SZ	Any other agreed analysis						

*Cu, including copper layer. Al < 0.030. **Ti: 0.10–0.20 Note: Single values are maximum.

Min. tensile properties two-run technique

Symbol	Parent material Rel/Rp0.2 (MPa)	Welded joint Rm (MPa)
2T	275	370
3T	355	470
4T	420	520
5T	500	500

Diffusible hydrogen in weld metal (optional)

Hydrogen content	
Symbol	ml/100g weld metal
H5	5
H10	10
H15	15

EN ISO 14171 — Cored wire type and all weld metal chemical composition (%)

Symbol	Mn	Ni	Mo	Cu
T2	1.4			0.3
T3	1.4–2.0			0.3
T2Mo	1.4		0.3–0.6	0.3
T3Mo	1.4–2.0		0.3–0.6	0.3
T2Ni1	1.4	0.6–1.2		0.3
T2Ni1.5	1.6	1.2–1.8		0.3
T2Ni2	1.4	1.8–2.6		0.3
T2Ni3	1.4	2.6–3.8		0.3
T3Ni1	1.4–2.0	0.6–1.2		0.3
T2Ni1Mo	1.4	0.6–1.2	0.3–0.6	0.3
T2Ni1Cu	1.4	0.8–1.2		0.3–0.6

Note: Single values are maximum.

EN ISO 24598-A: Solid wire electrodes, tubular cored electrodes and electrode-flux combinations for Submerged Arc welding of creep-resistant steels

Solid wire example:

SWX 150 / SDX CrMo1-EB2R

S S CrMo1 FB

S — Flux for Submerged Arc welding

Wire type

Symbol	Wire type
S	Solid wire
T	Cored wire

Mechanical properties all weld metal flux / (cored) wire combinations

Symbol	Min. yield strength MPa	Tensile strength MPa	Elongation %	CVN impact toughness at +20°C		Heat treatment		
				Av. of 3 min. J	Min. single value J	Preheat and interpass temperature °C	Post weld heat treatment °C	Time min.
Mo / MnMo	355	510	22	47	38	<200		
MoV	355	510	18	47	38	200–300	690–730	60
CrMo1	355	510	20	47	38	150–250	660–700	60
CrMoV1	435	590	15	24	21	200–300	680–730	60
CrMo2/CrMo2Mn	400	500	18	47	38	200–300	690–750	60
CrMo2L	400	500	18	47	38	200–300	690–750	60
CrMo5	400	590	17	47	38	200–300	730–760	60
CrMo9	435	590	18	34	27	200–300	740–780	120
CrMo91	415	585	17	47	38	250–350	750–760	180
CrMoWV12	550	690	15	34	27	250–350 or 400–500	740–780	120

Chemical composition all weld metal for flux / (cored) wire combinations

Symbol	C	Si	Mn	P	S	Cr	Ni	Mo	Cu	V	Other
Mo	0.15	0.80	1.4	0.030	0.030	0.2	0.3	0.40–0.65	0.35	0.03	Nb: 0.01
MnMo	0.15	0.80	2.0	0.030	0.030	0.2	0.3	0.40–0.65	0.35	0.03	Nb: 0.01
MoV	0.15	0.80	1.4	0.030	0.030	0.20–0.60	0.3	0.45–1.00	0.35	0.20–0.45	Nb: 0.01
CrMo1	0.15	0.80	1.20	0.030	0.030	0.80–1.30	0.25	0.35–0.65	0.40	0.03	Nb: 0.01
CrMoV1	0.15	0.80	1.40	0.030	0.030	0.80–1.30	0.3	0.80–1.30	0.35	0.10–0.35	Nb: 0.01
CrMo2	0.15	0.80	1.20	0.030	0.030	2.0–2.8	0.3	0.80–1.50	0.35	0.03	Nb: 0.01
CrMo2Mn	0.10	0.80	1.40	0.030	0.020	1.8–2.5	0.3	0.80–1.20	0.35	0.03	Nb: 0.01
CrMo2L	0.05	0.80	1.20	0.030	0.030	2.0–2.8	0.3	0.80–1.15	0.35	0.03	Nb: 0.01
CrMo5	0.10	0.80	1.20	0.030	0.030	4.50–6.50	0.3	0.45–0.80	0.35	0.03	Nb: 0.01
CrMo9	0.10	0.80	1.20	0.030	0.030	8.0–10.0	1.0	0.70–1.20	0.35	0.15	Nb: 0.01
CrMo91	0.15	0.80	1.80	0.030	0.030	8.0–10.5	1.0	0.70–1.20	0.35	0.10–0.30	Nb: 0.02–0.10
CrMoWV12	0.24	0.80	1.4	0.030	0.030	9.5–12.0	0.80	0.70–1.20	0.35	0.15–0.40	Nb: 0.01
Z	Any other agreed composition										

Note: Single values are maximum.

Flux type according to EN ISO 14174

Symbol	Flux type
MS	Manganese-silicate
CS	Calcium-silicate
ZS	Zirconium-silicate
RS	Rutile-silicate
AR	Aluminate-rutile
AB	Aluminate-basic
AS	Aluminate-silicate
AF	Aluminate-fluoride-basic
FB	Fluoride-basic
Z	Any other composition

ISO 26304-A: Solid wire electrodes, tubular cored electrodes and electrode-flux combinations for Submerged Arc welding of high-strength steels

Cored wire example:

SWX 150 / SubCOR SL 742
S 69 6 FB T3 Ni2.5CrMo

S — Flux for Submerged Arc welding

Tensile properties			
Symbol	Rel/Rp0.2 min. MPa	Rm MPa	A min. %
55	550	640–820	18
62	620	700–890	18
69	690	770–940	17
79	790	880–1080	16
89	890	940–1180	15

Impact properties	
Symbol	Min. 47J at °C
Z	No requirement
A	+20
0	0
2	-20
3	-30
4	-40
5	-50
6	-60

Flux type according to EN ISO 14174	
Symbol	Flux type
MS	Manganese-silicate
CS	Calcium-silicate
ZS	Zirconium-silicate
RS	Rutile-silicate
AR	Aluminate-rutile
AB	Aluminate-basic
AS	Aluminate-silicate
AF	Aluminate-fluoride-basic
FB	Fluoride-basic
Z	Any other composition

All weld metal chemical composition flux / cored wire combination (%)									
Symbol	C	Si	Mn	P	S	Cr	Ni	Mo	V
T3NiMo	0.05–0.12	0.20–0.60	1.30–1.90	0.02	0.02		0.60–1.00	0.15–0.45	
T3Ni1Mo	0.03–0.09	0.10–0.50	1.39–1.80	0.02	0.02		1.00–1.50	0.45–0.65	
T3Ni2MoV	0.03–0.09	0.20	1.20–1.70	0.02	0.02		1.60–2.00	0.20–0.50	0.05–0.15
T3Ni2Mo	0.03–0.09	0.40–0.80	1.30–1.80	0.02	0.02		1.80–2.40	0.20–0.40	
T3Ni3Mo	0.03–0.09	0.20–0.70	1.60–2.10	0.02	0.02		2.70–3.20	0.20–0.40	
T3Ni2.5CrMo	0.03–0.09	0.10–0.50	1.20–1.70	0.02	0.02	0.40–0.70	2.20–2.60	0.30–0.60	
T3Ni2.5Cr1Mo	0.04–0.10	0.20–0.70	1.20–1.70	0.02	0.02	0.70–1.20	2.20–2.60	0.40–0.70	
TZ	Any other agreed analyses								

Note: Single values are maximum.

Chemical composition wire (%)										
Symbol	C	Si	Mn	P	S	Cr	Ni	Mo	Cu	Other
S2Ni1Mo	0.07–0.15	0.05–0.25	0.80–1.30	0.020	0.020	0.20	0.80–1.20	0.45–0.65	0.30	
S3Ni1Mo	0.07–0.15	0.05–0.35	1.30–1.80	0.020	0.020	0.20	0.80–1.20	0.45–0.65	0.30	0.50
S3Ni1.5Mo	0.07–0.15	0.05–0.25	1.20–1.80	0.020	0.020	0.20	1.20–1.80	0.30–0.50	0.30	0.50
S2Ni2Mo	0.05–0.09	0.15	1.10–1.40	0.015	0.015	0.15	2.00–2.50	0.45–0.60	0.30	0.50
S2Ni3Mo	0.08–0.12	0.10–0.25	0.80–1.20	0.020	0.020	0.15	2.80–3.20	0.10–0.25	0.30	0.50
S3Ni1.5CrMo	0.07–0.14	0.05–0.15	1.30–1.50	0.020	0.020	0.15–0.35	1.50–1.70	0.30–0.50	0.30	0.50
S3Ni2.5CrMo	0.07–0.15	0.10–0.25	1.20–1.80	0.020	0.020	0.30–0.85	2.00–2.60	0.40–0.70	0.30	0.50
S1Ni2.5CrMo	0.07–0.15	0.10–0.25	0.45–0.75	0.020	0.020	0.50–0.85	2.10–2.60	0.40–0.70	0.30	0.50
S4Ni2CrMo	0.08–0.11	0.30–0.40	1.80–2.00	0.015	0.15	0.85–1.00	2.10–2.60	0.55–0.70	0.30	0.50
TZ	Any other agreed analyses									

Note: Single values are maximum.

Diffusible hydrogen in weld metal (optional)	
Hydrogen content	
Symbol	ml/100g weld metal
H5	5
H10	10
H15	15

SFA/AWS 5.17: Specification for carbon steel electrodes and fluxes for Submerged Arc welding

Cored wire example:

SWX 150 / SubCOR SL 731

F 7 A 4 - EC1

F — Flux for Submerged Arc welding

Tensile properties (multi-run)

	Tensile strength		Min. yield strength		Elongation
	psi	(MPa)	psi	(MPa)	%
6	60,000–80,000	(414–551)	48,000	(331)	22
7	70,000–95,000	(483–655)	58,000	(400)	22

Heat treatment

A	As welded
P	Post weld heat treated (PWHT) 620°C / 1h

Impact properties

	Temperature		Charpy-V impact min.	
	°F	(°C)	ft-lb	(J)
0	0	(-18)	20	(27)
2	-20	(-29)	20	(27)
4	-40	(-40)	20	(27)
5	-50	(-46)	20	(27)
6	-60	(-51)	20	(27)
8	-80	(-62)	20	(27)
Z	No requirements			

Chemical composition for composite electrode weld metal (%)

Classification	C	Mn	Si	S	P	Cu
EC1	0.15	1.80	0.90	0.35	0.035	0.35
ECG	Not specified					

Note: Single values are maximum.

Chemical composition for solid electrodes (%) (extract)

Classification	C	Mn	Si	S	P	Cu
EL8	0.10	0.25–0.60	0.07	0.030	0.030	0.35
EL8K	0.10	0.25–0.60	0.10–0.25	0.030	0.030	0.35
EL12	0.04–0.14	0.25–0.60	0.10	0.030	0.030	0.35
EM12	0.06–0.15	0.80–1.25	0.10	0.030	0.030	0.35
EM12K	0.05–0.15	0.80–1.25	0.10–0.35	0.030	0.030	0.35
EH12K	0.06–0.15	1.50–2.00	0.25–0.65	0.025	0.025	0.35
EH14	0.10–0.20	1.70–2.20	0.10	0.030	0.030	0.35

Note: Single values are maximum.

Diffusible hydrogen in weld metal (optional)

Hydrogen content	
Symbol	ml/100g weld metal
H2	2
H4	4
H8	8
H16	16

SFA/AWS 5.23: Specification for low-alloy steel electrodes and fluxes for Submerged Arc welding

Solid wire example:

SWX 150 / SDX S2Ni2-ENi2

F 8 A 10 - ENi2 - Ni2

F — Flux for Submerged Arc welding

Tensile properties (multi-run)

	Tensile strength		Min. yield strength		Elongation %
	psi	(MPa)	psi	(Mpa)	
7	70,000–95,000	(483–655)	58,000	(400)	22
8	80,000–100,000	(552–698)	68,000	(469)	20
9	90,000–110,000	(621–758)	78,000	(538)	17
10	100,000–120,000	(689–827)	88,000	(607)	16
11	110,000–130,000	(758–896)	98,000	(676)	15
12	120,000–140,000	(827–965)	108,000	(745)	14
13	130,000–150,000	(896–1034)	118,000	(814)	14

Heat treatment

A	As welded
P	Post weld heat treated (PWHT)— time and temperature varies by alloy

Impact properties

Z	Temperature		Charpy-V impact min.	
	°F	(°C)	ft-lb	(J)
0	0	(-18)	20	(27)
2	-20	(-29)	20	(27)
4	-40	(-40)	20	(27)
5	-50	(-46)	20	(27)
6	-60	(-51)	20	(27)
8	-80	(-62)	20	(27)
10	-100	(-73)	20	(27)
15	-150	(-101)	20	(27)
Z	No requirements			

Chemical composition for solid electrodes (%) (extract)

Classification	C	Mn	Si	S	P	Cr	Ni	Mo	Cu	Other
EA2	0.05–0.17	0.95–1.35	0.20	0.025	0.025			0.45–0.65	0.35	
EA3	0.05–0.17	1.65–2.20	0.20	0.025	0.025			0.45–0.65	0.35	
EA4	0.05–0.15	1.20–1.70	0.20	0.025	0.025			0.45–0.65	0.35	
EB2	0.07–0.15	0.45–1.00	0.05–0.30	0.025	0.025	1.00–1.75		0.45–0.65	0.35	
EB2R	0.07–0.15	0.45–1.00	0.05–0.30	0.010	0.010	1.00–1.75		0.45–0.65	0.15	As: 0.005 Sn: 0.005 Sb: 0.005
EB3	0.05–0.15	0.40–0.80	0.05–0.30	0.025	0.025	2.25–3.00		0.90–1.10	0.35	
EB3R	0.05–0.15	0.40–0.80	0.05–0.30	0.010	0.010	2.25–3.00		0.90–1.00	0.15	As: 0.005 Sn: 0.005 Sb: 0.005
EF2	0.10–0.18	1.70–2.40	0.20	0.025	0.025		0.40–0.80	0.40–0.65	0.35	
EF3	0.10–0.18	1.50–2.40	0.30	0.025	0.025		0.70–1.10	0.40–0.65	0.35	
EF5	0.10–0.17	1.70–2.20	0.20	0.015	0.010	0.25–0.50	2.30–2.80	0.45–0.65	0.50	
EM4	0.10	1.40–1.80	0.20–0.60	0.015	0.015	0.60	2.30–2.80	0.30–0.65	0.25	Ti: 0.10 Zr: 0.10 Al: 0.10
ENi1	0.12	0.75–1.25	0.05–0.30	0.020	0.020	0.15	0.75–1.25	0.30	0.35	
ENi2	0.12	0.75–1.25	0.05–0.30	0.020	0.020		2.10–2.90		0.35	
ENi5	0.12	1.20–1.60	0.05–0.30	0.020	0.020		0.75–1.25	0.10–0.30	0.35	
ENi3	0.13	0.60–1.20	0.05–0.30	0.020	0.020	0.15	3.10–3.80		0.35	
EG	Not specified									

Note: Single values are maximum.

Chemical composition of weld metal (%) (extract)

Classification	C	Mn	Si	S	P	Cr	Ni	Mo	Cu	Other
A2	0.12	1.40	0.80	0.030	0.030			0.40–0.65	0.35	
A3	0.15	2.10	0.80	0.030	0.030			0.40–0.65	0.35	
A4	0.15	1.60	0.80	0.030	0.030			0.40–0.65	0.35	
B2	0.05–0.15	1.20	0.80	0.030	0.030	1.00–1.50		0.40–0.65	0.35	
B2R	0.05–0.15	1.20	0.80	0.010	0.010	1.00–1.50		0.40–0.65	0.15	As: 0.005 Sn: 0.005 Sb: 0.005
B3	0.05–0.15	1.20	0.80	0.030	0.030	2.00–2.50		0.90–1.20	0.35	
B3R	0.05–0.15	1.20	0.80	0.010	0.010	2.00–2.50		0.90–1.20	0.15	As: 0.005 Sn: 0.005 Sb: 0.005
F2	0.17	1.25–2.25	0.80	0.030	0.030		0.40–0.80	0.40–0.65	0.35	
F3	0.17	1.25–2.25	0.80	0.030	0.030		0.70–1.10	0.40–0.65	0.35	
F5	0.17	1.20–1.80	0.80	0.020	0.020	0.65	2.00–2.80	0.30–0.80	0.50	
M4	0.10	1.30–2.25	0.80	0.020	0.020	0.80	2.00–2.80	0.30–0.80	0.30	Ti+V+Zr: 0.03
Ni1	0.12	1.60	0.80	0.025	0.030	0.15	0.75–1.10	0.35	0.35	Ti+V+Zr: 0.05
Ni2	0.12	1.60	0.80	0.025	0.030		2.00–2.90		0.35	
Ni5	0.12	1.60	0.80	0.025	0.030		0.70–1.10	0.10–0.30	0.35	
Ni3	0.12	1.60	0.80	0.025	0.030	0.15	2.80–3.80		0.35	
EG	Not specified									
EC	Composite electrode									

Note: Single values are maximum.

EN ISO 14343-A: Welding consumables — wire electrodes, strip electrodes, wires and rods for arc welding of stainless and heat-resistant steels — classification according to nominal composition

Solid wire example:

SWX 220 / SDX 309LMo

S 23 12 2 L

Symbol for the arc welding process

G	Gas metal arc welding
W	Gas tungsten arc welding
P	Plasma welding
S	Submerged arc welding or electroslag strip cladding
L	Laser beam welding

Extract	Chemical composition (%)											
Austenitic types	C	Si	Mn	P	S	Cr	Ni	Mo	N	Cu	Nb	Others
19 9 L (308L)	0.03	0.65	0.8	0.03	0.02	19.0–21.0	9.0–11.0	0.5		0.5		
23 12 L (309L)	0.03	0.65	1.0–2.5	0.03	0.02	22.0–25.0	11.0–14.0	0.5		0.5		
23 12 2 L (309LMo)	0.03	1.0	1.0–2.5	0.03	0.02	21.0–25.0	11.0–15.5	2.0–3.5		0.5		
19 12 3 L (316L)	0.03	0.65	1.0–2.5	0.03	0.02	18.0–20.0	11.0–14.0	2.5–3.0		0.5		
19 13 4 L (317L)	0.03	1.0	1.0–1.5	0.03	0.02	17.0–20.0	12.0–15.0	3.0–4.5		0.5		
19 9 Nb (347)	0.08	0.65	1.0–2.5	0.03	0.02	19.0–21.0	9.0–11.0	0.5		0.5	10xC-1.0	
Austenitic ferritic types												
22 9 3 N L (2209)	0.03	1.0	2.5	0.03	0.02	21.0–24.0	7.0–10.0	2.5–4.0	0.10–0.20	0.5		
25 9 4 N L (2594)	0.03	1.0	2.5	0.03	0.02	24.0–27.0	8.0–10.5	2.5–4.5	0.20–0.30	1.5		W: 1.0

Note: Single values are maximum.

SFA/AWS A5.9: Bare stainless steel welding electrodes and rods (extract)

Example:

SDX 316L

ER 316L

ER — Solid wire

Chemical composition wire (%)												
AWS	C	Si	Mn	P	S	Cr	Ni	Mo	N	CU	Others	
ER308L	0.03	0.30–0.65	1.0–2.5	0.03	0.03	19.5–22.0	9.0–11.0	0.75		0.75		
ER308H	0.04–0.08	0.30–0.65	1.0–2.5	0.03	0.03	19.5–22.0	9.0–11.0	0.50		0.75		
ER309L	0.03	0.30–0.65	1.0–2.5	0.03	0.03	23.0–25.0	12.0–14.0	0.75		0.75		
ER309LMo	0.03	0.30–0.65	1.0–2.5	0.03	0.03	23.0–25.0	12.0–14.0	2.0–3.0		0.75		
ER310	0.08–0.15	0.30–0.65	1.0–2.5	0.03	0.03	25.0–28.0	20.0–22.5	0.75		0.75		
ER316L	0.03	0.30–0.65	1.0–2.5	0.03	0.03	18.0–20.0	11.0–14.0	2.0–3.0		0.75		
ER317L	0.03	0.30–0.65	1.0–2.5	0.03	0.03	18.5–20.5	13.0–15.0	3.0–4.0		0.75		
ER347	0.08	0.30–0.65	1.0–2.5	0.03	0.03	19.0–21.5	9.0–11.0	0.75		0.75	Nb=10xCmin/1.0max	
ER2209	0.03	0.90	0.50–2.0	0.03	0.03	21.5–23.5	7.5–9.5	2.5–3.5	0.08–0.20	0.75		

Note: Single values are maximum.



Submerged Arc Welding Equipment

Miller® Submerged Arc Solutions



Built for you ... to build with you.

Miller develops high-quality, reliable welding solutions that deliver exceptional performance for our customers. We back the products we build with the most responsive support and service. And together, with the skilled, dedicated welders who use our products, we build lasting work that benefits the world.



With the advanced line of Miller® SubArc Digital Series equipment, you'll experience solutions developed for nearly every Submerged Arc welding application. Easy to install, easy to integrate and easy to operate with new or existing systems, Miller Submerged Arc solutions provide robust performance and exceptional reliability, giving you the power to get jobs done. It's what you expect when you build with Miller.



If you need skilled technical assistance to equip your business, your Miller Submerged Arc welding professionals can evaluate your existing processes, recommend options for improvements and help put your plans into action for real benefits.

Miller SubArc Digital Series equipment is tested with precisely formulated Hobart® filler metal and flux solutions, and we recommend their use. As ITW Welding companies, both Hobart and Miller share a commitment to your complete satisfaction.



Contact your Miller Submerged Arc professional today and optimize your processes to their full potential.

Table of Contents

Technology Increases SAW Deposition Rates	4
Miller Submerged Arc System	5
SubArc DC 650/800 Digital and SubArc DC 1000/1250 Digital	5
SubArc AC/DC 1000/1250 Digital	5
SubArc Interface Digital	5
SAW Accessories	6
Wire Drive Assemblies	6
SubArc Flux Hopper Digital Low Voltage	6
Compressed Air Flux Feeder	6
Single-Wire Straightener	6
Twin-Wire Straightener	6
Submerged Arc Torches System	7
OBT 600	7
OBT 1200	7
1200-Amp Single-Wire Torch — Short	7
1200-Amp Twin-Wire Torch — Short/Long	7
Single-Wire Narrow Gap Torch	7
Tandem-Wire Narrow Gap Torch	7
Single-Wire Narrow Gap Flat Torch	7
Cladding Heads (external and internal)	8
60 mm Cladding Head	8
90 mm Cladding Head	8
120 mm Cladding Head	8
8" Diameter Head	8
10" Diameter Head	8
12" Diameter Head	8
Accessories	9
Magnetic Steering Device	9
Strip De-Reeler	9
SubArc Tractor	9
Induction Heating	10
Induction Heating System	11
ProHeat™ Rolling Inductor	11

Disclaimer: The information contained or otherwise referenced herein is for reference purposes only and is presented only as “typical”. Typical data are those obtained when welding and testing are performed in accordance with applicable AWS and/or EN ISO specifications. Other tests and procedures may produce different results and typical data should not be assumed to yield similar results in a particular application or weldment. No data is to be construed as a recommendation for any welding condition or technique not controlled by Miller and Hobart. Miller and Hobart do not assume responsibility for any results obtained by persons over whose methods it has no control. It is the user’s responsibility to determine the suitability of any products or methods mentioned herein for a particular purpose. In light of the foregoing, Miller and Hobart specifically disclaim any liability incurred from reliance on such information, and disclaims all guarantees and warranties, express or implied, including warranties of merchantability and fitness for a particular purpose, and further disclaims any liability for consequential or incidental damages of any kind, including lost profits.

Technology Increases SAW Deposition Rates

SubArc AC/DC 1000/1250 Digital Submerged Arc Welding Power Source

Variable balance AC/DC squarewave Submerged Arc welding (SAW) technology from Miller overcomes the traditional problems or limitations of SAW with all other processes including DC electrode positive (DCEP), DC electrode negative (DCEN) and traditional AC.



The SubArc AC/DC 1000/1250 Digital gives full control over AC wave balance and frequency

- Maximized deposition rate. 30% higher or more is feasible, using the same parameters
- Smaller angles and lower filler metal consumption
- Reduced heat input, minimized distortion and increased mechanical properties
- Penetration control to minimize the risk of lack of fusion
- Minimized magnetic arc blow
- Reduced arc interactions in multi-wire processes
- Control of bead shape
- Excellent arc start
- Improved arc stability compared to traditional AC
- Substantially lower power consumption
- Reduced weld over thickness

The SubArc AC/DC 1000/1250 Digital has a choice of 14 most commonly used balance/frequency combinations and user-friendly setting.

Balance selection, indicated by BL.FR in the upper display, adjusts the AC balance and frequency, shown on the lower display. The first two digits indicate the positive balance value followed by a decimal point. The two digits after the decimal point indicate frequency. Balance and frequency are dependent on one another, and cannot be individually adjusted.

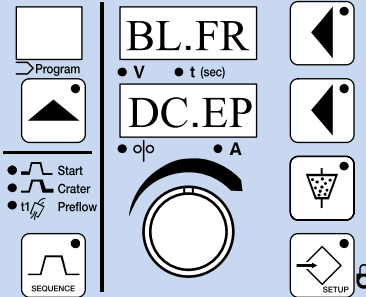

Balance/frequency combinations

Balance	Frequency	
	60Hz line	50Hz line
Electrode positive	--	--
80/20	18	15
75/25	23	19
70/30	18	15
67/33	30	25
60/40	18	15
50/50	30	25
50/50	18	15
40/60	18	15
33/67	30	25
30/70	18	15
25/75	23	19
20/80	18	15
Electrode negative	--	--

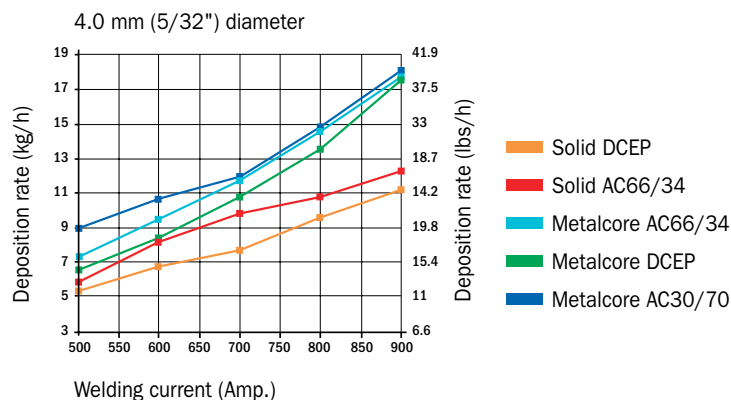

Penetration profiles

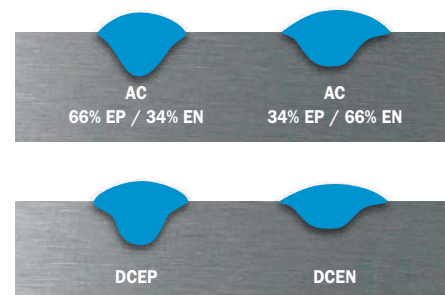

Submerged Arc System

SubArc DC 650/800 and DC 1000/1250 Digital Submerged Arc Welding Power Source

Three-phase, CC/CV DC power sources are designed to provide a superior arc for the Submerged Arc (SAW) and Electroslag (ESW) welding processes, as well as Air Carbon Arc gouging, plus the endurance to handle demanding industrial applications.



PROCESSES

- Submerged Arc (SAW)
- Electroslag (ESW)
- Air Carbon Arc Cutting and Gouging (CAC-A)

CHARACTERISTICS

- CC/CV
- DC
- Requires three-phase power
- 24 VAC low-voltage control power
- Easy to integrate, Modbus® digital interface

SubArc DC 650 / 800 Digital

- Amperage 50–815 A
- Voltage 20–44 V
- Rated output 650 A at 44 V (100% duty cycle)

SubArc DC 1000 / 1250 Digital

- Amperage 100–1250 A
- Voltage 20–44 V
- Rated output 1000 A at 44 V (100% duty cycle)

SubArc AC/DC 1000/1250 Digital Submerged Arc Welding Power Source

Three-phase squarewave AC/DC machine with phase-shifting capability with steps to refine arc. AC/DC squarewave provides excellent quality of penetration/bead profile and high performance in deposition rate with low heat input (increased mechanical properties and reduced distortion).



PROCESS

- Submerged Arc (SAW)
- Electroslag (ESW)

CHARACTERISTICS

- CC/CV
- AC/DC variable squarewave
- Requires three-phase power
- Easy to integrate, Modbus® digital interface
- 24 VAC low-voltage control power
- Frequencies 10–90 Hz
- Amperage 300–1250 A
- Voltage 20–44V
- Rated output 1000 A at 44 VDC (100% duty cycle)

SubArc Interface Digital Automatic Weld Control

Automatic digital weld controllers offer reliability, flexibility and performance with their ability to interface with SubArc Digital power sources.



PROCESSES

- Submerged Arc (SAW)
- Electroslag (ESW)

CHARACTERISTICS

- Supply 24 VAC
- Adjustable start and crater parameters
- Amperage/voltage/WFS range look
- Memory for up to 15 programs
- Arc time and arc cycles
- Ability to change programs during welding operation
- Terminal block for easy integration of hard automation or remote control
- CV+C mode allows operator to preset voltage and amperage rather than wire feed speed

SAW Accessories

Wire Drive Assemblies

Miller offers heavy-duty, low-voltage (38 VDC) wire drive assemblies.



CHARACTERISTICS

- SubArc Strip Drive 100 Digital Low Voltage (ESW)
 - Low-speed, for strip cladding, 0.3–3.2 m/min (10–125 IPM)
- SubArc Wire Drive 400 Digital Low Voltage
 - Standard-speed, 0.8–10.2 m/min (30–400 IPM)
- SubArc Wire Drive 780 Digital Low Voltage
 - High-speed, 1.3–19.8 m/min (50–780 IPM)



SubArc Flux Hopper Digital Low Voltage

Automatic flux valve will carry 11.3 kg (25 lbs) of flux. The opening is sized to allow hook-up of any flux-hopper-mounted recovery system. A slag screen is also provided.



DESCRIPTION

- 11.3 kg (25 lbs) capacity
- Power supply 24 V
- 12 VDC solenoid valve



Compressed Air Flux Feeder

The automatic air compressed flux feeding system is electronically controlled to enable preheated flux to be kept at a constant temperature.



CHARACTERISTICS

- Storage capacity from 120–205 l (32–205 gal)
- Working temperature 100°C (212°F)
- Voltage supply 220 V
- Max input power 2800 W
- Max air pressure 6 bar (87 psi)



Single-Wire Straightener

For use with SubArc Wire Drive 400 Digital Low Voltage or 780 Digital Low Voltage.



DESCRIPTION

- For 1.6–5.6 mm (1/16–7/32") wires.



Twin-Wire Straightener

For use with twin-wire torches only. Single or double/separate adjustment models available.



DESCRIPTION

- For 1.2–2.4 mm (.045–3/32") wires.



Submerged Arc Torches System

OBT 600

600-amp, 100% duty cycle torch with concentric flux flow nozzle.



PROCESS

- Submerged Arc (SAW)
- Wire diameter 1.6–5.6 mm (1/16–7/32")



OBT 1200

1200-amp, 100% duty cycle torch with concentric flux flow nozzle.



PROCESS

- Submerged Arc (SAW)
- Wire diameter 1.6–5.6 mm (1/16–7/32")



Single-Wire Narrow Gap Torch

1200-amp, 100% duty cycle torch for narrow gap.



PROCESS

- Submerged Arc (SAW)
- Wire diameter 2.4–4.0 mm (3/32–5/32")
- For depth 50–350 mm (2–14")
- PTFE insulation up to 200°C (390°F)
- Ceramic insulation up to 350°C (660°F)



1200-Amp Single-Wire Torch — Short

1200-amp, 100% duty cycle torch.



PROCESS

- Submerged Arc (SAW)
- Wire diameter 1.6–4.0 mm (1/16–5/32")

Short model: single-wire welding nozzle with an effective length of 220 mm (5.6").



Tandem-Wire Narrow Gap Torch

800-amp, 100% duty cycle torch for narrow gap.



PROCESS

- Submerged Arc (SAW)
- Wire diameter 2.4–4.0 mm (3/32–5/32")
- For depth 50–350 mm (2–14")
- PTFE insulation up to 200°C (390°F)
- Ceramic insulation up to 350°C (660°F)



1200-Amp Twin-Wire Torch — Short / Long

1200-amp, 100% duty cycle twin-wire torches with concentric flux flow nozzle.



PROCESS

- Submerged Arc (SAW twin)
- Wire diameter 1.2–2.4 mm (.045–3/32")

Short model: twin-arc welding torch with an effective length of 220 mm (8.7").

Long model: twin-arc welding torch with an effective length of 360 mm (14.2").

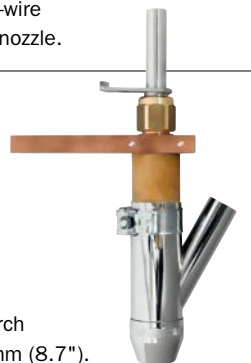

Single-Wire Narrow Gap Flat Torch

800-amp, 100% duty cycle torch for narrow gap.



PROCESS

- Submerged Arc (SAW)
- Wire diameter 2.4–4.0 mm (3/32–5/32")
- For depth 100–250 mm (4–10")
- Ceramic insulation up to 350°C (660°F)



Cladding Heads

For Standard Application

It is recommended that all cladding SAW/ESW heads are used in conjunction with the SubArc Strip Drive 100 Digital Low Voltage.

For Nozzle and Pipe Application

The following head is designed for SAW/ESW, both circumferential and longitudinal cladding.

60 mm Cladding Head

CHARACTERISTICS

- Max current 2000 A (100% duty cycle)
- Dimension 200 x 230 x 360 mm (8 x 9 x 14")
- Weight 13.5 kg (29.7 lbs)
- Water cooled
- Strip width 30–60 mm (1-3/16–2-3/8")

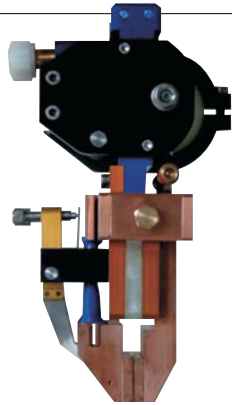

8" Diameter Head

CHARACTERISTICS

- Minimum inside diameter pipe clad 203 mm (8")
- Max current 750 A (100% duty cycle)
- Dimension 1349 x 150 x 150 mm (58-1/8 x 6 x 6")
- Weight 26.5 kg (59 lbs)
- Water cooled
- Strip width 30 mm (1-3/16")

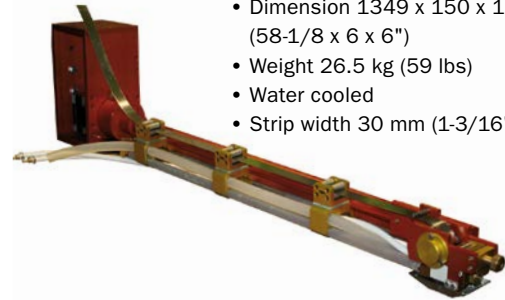

90 mm Cladding Head

CHARACTERISTICS

- Max current 3000 A (100% duty cycle)
- Dimension 220 x 230 x 400 mm (8 x 9 x 16")
- Weight 19 kg (41.8 lbs)
- Water cooled
- Strip width 30 – 60 – 90 mm (1-3/16 – 2-3/8 – 3-1/2")



10" Diameter Head

CHARACTERISTICS

- Minimum inside diameter pipe clad 260 mm (10")
- Max current 850 A (100% duty cycle)
- Dimension 1349 x 200 x 200 mm (58-1/8 x 8 x 8")
- Weight 27 kg (60 lbs)
- Water cooled
- Strip width 30 mm (1-3/16")

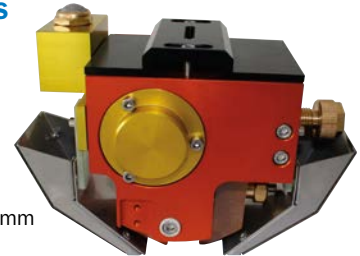

120 mm Cladding Head

CHARACTERISTICS

- Max current 3600 A (100% duty cycle)
- Dimension 230 x 230 x 470 mm (8 x 9 x 19")
- Weight 25 kg (55 lbs)
- Water cooled
- Strip width 60 – 90 – 120 mm (2-3/8 – 3-1/2 – 4-3/4")

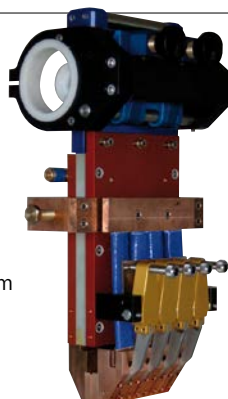

12" Diameter Head

CHARACTERISTICS

- Minimum inside diameter pipe clad 310 mm (12")
- Max current 1000 A (100% duty cycle)
- Dimension 1349 x 240 x 225 mm (58-1/8 x 9-1/2 x 9")
- Weight 27.5 kg (61 lbs)
- Water cooled
- Strip width 30 mm (1-3/16")

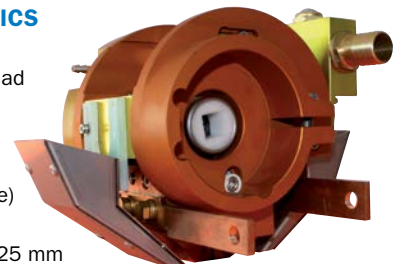

Accessories

Magnetic Steering Device

The magnetic steering device is intended for use with the ESW process. When used with stainless steel and nickel-base strip and fluxes, it ensures that the cladding process achieves uniformity, in terms of level and uniform weld bead edge formation. Additionally it controls the weld bead ripple formation which maintains the consistency of both bond integrity and appearance.



CHARACTERISTICS

- Weight 15 kg (33 lbs)
- Dimension 530 x 280 x 400 mm (21 x 11 x 16")
- Power 220 V/110 V, 50–60 Hz
- Solenoid 10 A, 24 VDC (red)/strip 90–120 mm (3.5–4.7")



Strip De-Reeler



Strip spool holder from 150–1.000 kg (330–2200 lbs) with adjustable inner diameter.



SubArc Tractor

A motorized, highly flexible welding tractor designed to produce, high-quality Submerged Arc welds.



PROCESS

- Submerged Arc (SAW)
- For use with Miller
 - SubArc DC 650/800 Digital
 - SubArc DC 1000/1250 Digital
 - SubArc AC/DC 1000/1250 Digital

PACKAGE INCLUDES

- Tractor with remote start/stop control and guide rolls
- SubArc Interface
- SubArc Wire Drive 400 for Tractor
- SubArc Flux Hopper Digital Low Voltage
- 27-kg (60 lb) wire reel
- OBT 600
- Wire straightener



Induction Heating

Induction heating is a proven technology that has been used for years in industrial and construction applications involving welding. Companies with welding-intensive operations have significantly increased efficiency by switching to induction for preheating before welding and stress relieving after welding. Compared to conventional preheating and stress relieving methods, induction heating offers numerous advantages.

- Low consumable costs. No fuel costs and minimal insulation costs.
- Uniform heating is maintained along and through the heat zone by using induction to heat within the material. The surface of the part is not marred by localized conducted heat at higher than specified temperatures.
- Time-to-temperature is faster than conventional processes due to the method of applying the heat, reducing heating cycle time.



- Improved working environment is created during welding. Welders are not exposed to open flame, explosive gases and hot elements associated with fuel gas heating and resistance heating.
- Easy setup is achieved using preheat blankets, flexible heating cables or the Rolling Inductor.

How It Works

Induction heating systems induce heat electromagnetically rather than using a heating element in contact with a part to conduct heat, as does resistance heating. Induction heating acts more like a microwave oven; the appliance remains cool while the food cooks from within.

In an industrial example of induction heating, heat is induced in the part by placing it in a high-frequency magnetic field. The magnetic field creates eddy currents inside the part, exciting the part's molecules and generating heat. Because heating occurs slightly below the metal surface, no heat is wasted.

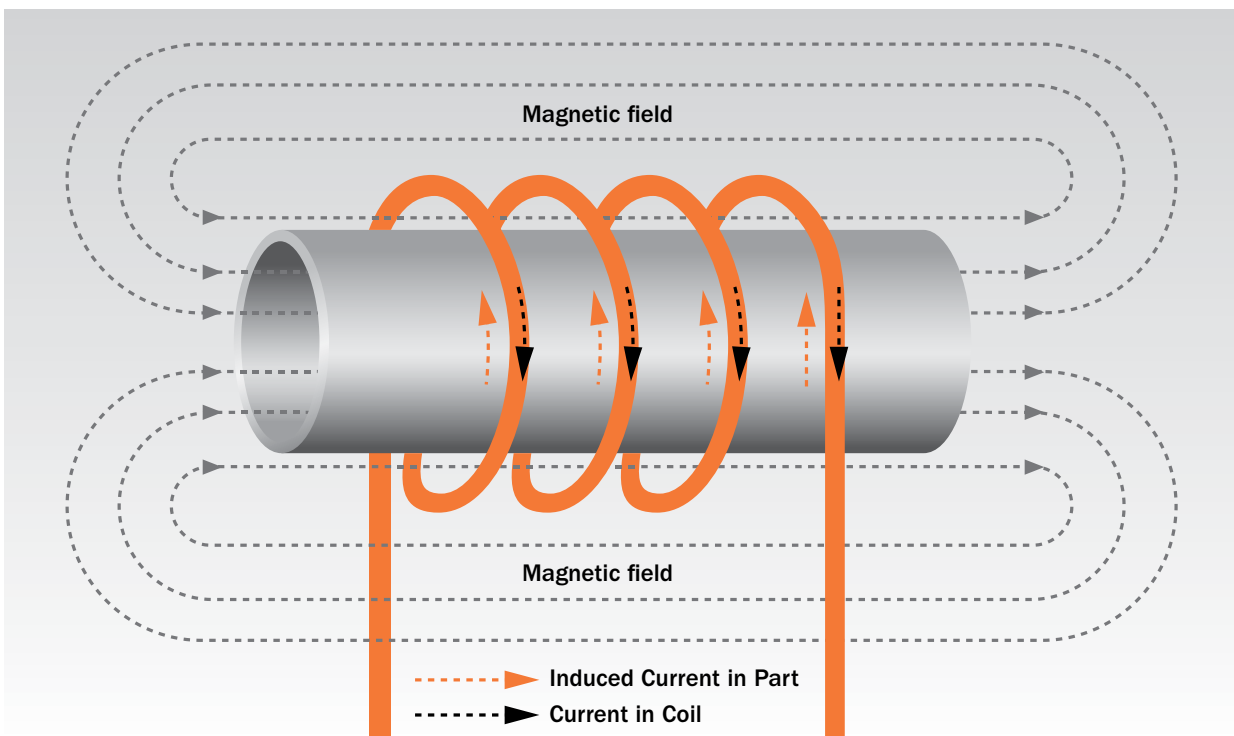

Induction Heating System

ProHeat™ Rolling Inductor Induction Heating System

The ProHeat 35 Induction Heating System with the Rolling Inductor is a simple and cost-effective heating process that can solve many preheating problems related to moving parts and deliver fast, consistent heat.



APPLICATIONS

- Process piping
- Refinery
- Petrochemical
- Power piping
- Pressure vessels

BENEFITS

- **Maximum productivity**
 - Quick time to temperature
 - Continuous fabrication
 - No coiling of cable
- **Improved safety**
 - Eliminates open flames
 - Cooler shop environment and reduced operator fatigue
- **Optimal consistency and quality**
 - Even distribution of heat eliminates quality issues
- **Easy to use**
 - Simple setup and operation
 - Flexible and portable for a wide range of applications

Specially designed for heating moving parts.



ProHeat 35 Liquid-Cooled System with Rolling Inductor.

(Pipe stands sold separately.)



Rolling Inductor Specifications

Rated Output	Ambient Temperature Range Storage Usage	Maximum Part Preheat Temperature	Required Cooler	Dimensions	Shipping Weight
300 amps at 100% duty cycle	-40°C to 82°C (-40°F to 180°F)	0°C to 60°C (32°F to 140°F)	Miller Heavy-Duty Induction Cooler (#951 142)	H: 133 mm (5.25") W: 168 mm (6.6") D: 203 mm (8")	18.1 kg (40 lbs)